

---

Operating instructions and spare parts list

# Magic Control CM-10

## Plant control

**TW**  
**Gema**



**Documentation Magic Control CM-10 Plant control**

© Copyright 2005 ITW Gema GmbH

All rights reserved.

This publication is protected by copyright. Unauthorized copying is prohibited by law. No part of this publication may be reproduced, photocopied, translated, stored on a retrieval system or transmitted in any form or by any means for any purpose, neither as a whole nor partially, without the express written consent of ITW Gema GmbH.

OptiTronic, OptiGun, EasyTronic, EasySelect, OptiFlow and Super-Corona are registered trademarks of ITW Gema GmbH.

OptiMatic, OptiMove, OptiMaster, OptiPlus, MultiTronic and Gematic are trademarks of ITW Gema GmbH.

All other product names are trademarks or registered trademarks of their respective holders.

Reference is made in this manual to different trademarks or registered trademarks. Such references do not mean that the manufacturers concerned approve of or are bound in any form by this manual. We have endeavored to retain the preferred spelling of the trademarks, and registered trademarks of the copyright holders.

To the best of our knowledge and belief, the information contained in this publication was correct and valid on the date of issue. ITW Gema GmbH makes no representations or warranties with respect to the contents or use of this publication and reserves the right to revise this publication and make changes to its content without prior notice.

**Printed in Switzerland**

ITW Gema GmbH  
Mövenstrasse 17  
9015 St. Gallen  
Switzerland

Phone: +41-71-313 83 00  
Fax.: +41-71-313 83 83

E-Mail: [info@itwgema.ch](mailto:info@itwgema.ch)  
Homepage: [www.itwgema.ch](http://www.itwgema.ch)

# Table of contents

<b>General safety regulations</b>	<b>3</b>
Safety symbols (pictograms).....	3
Conformity of use.....	3
Technical safety regulations for stationary electrostatic powder spraying equipment .....	4
General information .....	4
Safety conscious working .....	5
Individual safety regulations for the operating firm and/or operating personnel.....	5
Notes on special types of hazard.....	6
Safety requirements for electrostatic powder coating.....	7
A summary of the rules and regulations .....	8
Product specific security measures .....	10
<b>About this manual</b>	<b>11</b>
General information .....	11
Software version .....	11
<b>Function description</b>	<b>13</b>
Field of application .....	13
Magic Control CM-10 - overview.....	13
Typical characteristics.....	13
Differences CM-10 / CM-20 .....	13
<b>Technical Data</b>	<b>15</b>
Magic Control CM-10 Plant control.....	15
System .....	15
Electrical data .....	15
Display .....	15
Dimensions .....	16
Connections .....	16
Environmental conditions.....	16
<b>Start-up</b>	<b>17</b>
General information .....	17
General operating instructions .....	17
Symbols .....	17
Function keys .....	18
Light grid check.....	20
Touch key fields .....	20
Menu structure .....	22
Starting the equipment.....	23
General information .....	23
Edit axis values, select or deselect.....	25
Edit gun values, select or deselect .....	25

<b>Operating modes</b>	<b>27</b>
Overview .....	27
Manual operating mode .....	28
Edit axis values, select or deselect axes .....	28
Edit gun values and select or deselect .....	29
Daily correction, select or deselect guns .....	30
Axes start independent of the conveyor .....	30
Guns start independent of the conveyor .....	31
Automatic operation mode .....	32
Simulation of the CAN bus sensor .....	32
Cleaning operation mode .....	33
<b>Parameterization</b>	<b>35</b>
Equipment parameterization .....	35
Main page .....	35
General parameters .....	36
Station parameters .....	37
Calibration of the CAN bus sensor .....	38
Booth parameters .....	39
Light grid evaluation for gun switch-off .....	40
Light grid evaluation for stroke switching and gradually adaptation of sinus .....	41
<b>Object data administration</b>	<b>43</b>
Load and save object data .....	43
Copy and insert object data .....	44
Name object data .....	44
<b>Error display / diagnostics</b>	<b>45</b>
Error display main page .....	45
Activated CAN bus devices .....	46
Check digital inputs, set and delete outputs .....	47
Operating hours administration .....	48
<b>User levels and access</b>	<b>51</b>
Log-in .....	51
User level 0 .....	51
User level 1 .....	51
User level 2 .....	52
User level 3 .....	52
No user level .....	52
<b>Plant configuration</b>	<b>53</b>
General information .....	53
Settings .....	54
Overview .....	54
Keys .....	55
<b>Spare parts list</b>	<b>57</b>
Ordering spare parts .....	57
Magic Control CM-10 - complete .....	58

# General safety regulations

This chapter sets out the fundamental safety regulations that must be followed by the user and third parties using the Magic Control CM-10 Plant control.

These safety regulations must be read and understood before the Magic Control CM-10 Plant control is used.

---

## Safety symbols (pictograms)

The following warnings with their meanings can be found in the ITW Gema operating instructions. The general safety precautions must also be followed as well as the regulations in the operating instructions.

**DANGER!**

Danger due to live electricity or moving parts. Possible consequences: Death or serious injury

**WARNING!**

Improper use of the equipment could damage the machine or cause it to malfunction. Possible consequences: minor injuries or damage to equipment

**INFORMATION!**

Useful tips and other information



---

## Conformity of use

1. The Magic Control CM-10 Plant control is built to the latest specification and conforms to the recognized technical safety regulations. It is designed for the normal application of powder coating.
2. Any other use is considered as non-conform. The manufacturer is not responsible for damage resulting from improper use of this equipment; the end-user alone is responsible. If the Magic Control CM-10 Plant control is to be used for other purposes or other substances outside of our guidelines then ITW Gema GmbH should be consulted.
3. Observance of the operating, service and maintenance instructions specified by the manufacturer is also part of conformity of

use. The Magic Control CM-10 Plant control should only be used, maintained and started up by trained personnel, who are informed about and are familiar with the possible hazards involved.

4. Start-up (i.e. the execution of a particular operation) is forbidden until it has been established that the Magic Control CM-10 Plant control has been set up and wired according to the guidelines for machinery (98/37 EG). EN 60204-1 (machine safety) must also be observed.
5. Unauthorized modifications to Magic Control CM-10 Plant control exempts the manufacturer from any liability from resulting damage.
6. The relevant accident prevention regulations, as well as other generally recognized safety regulations, occupational health and structural regulations are to be observed.
7. Furthermore the country-specific safety regulations must be observed.

Explosion protection	Protection type	Temperature class
  II (2) D	IP54	T6 (zone 21) T4 (zone 22)

## Technical safety regulations for stationary electrostatic powder spraying equipment

### General information

The powder spraying equipment of ITW Gema is designed with safety in mind and is built according to the latest technological specifications. This equipment can be dangerous if it is not used for its specified purpose. Consequently it should be noted that there exists a danger to life and limb of the user or third party, a danger of damage to the equipment and other machinery belonging to the user and a hazard to the efficient operation of the equipment.

1. The powder spraying equipment should only be started up and used once the operating instructions have been carefully studied. Improper use of the controlling device can lead to accidents, malfunction or damage to the control itself.
2. Before every start-up check the equipment for operational safety (regular servicing is essential)!
3. Safety regulations BGI 764 and VDE regulations DIN VDE 0147, part 1, must be observed for safe operation.
4. Safety precautions specified by local legislation must be observed!
5. The plug must be disconnected before the machine is opened for repair!
6. The plug and socket connection between the powder spraying equipment and the mains network should only be taken out when the power is switched off.
7. The connecting cables between the controlling device and the spray gun must be set up so that it cannot be damaged during

operation. Safety precautions specified by local legislation must be observed!

8. Only original ITW Gema spare parts should be used, because the explosion protection will also be preserved that way. Damage caused by other parts is not covered by guarantee.
9. If ITW Gema powder spraying equipment is used in conjunction with machinery from other manufacturers then their safety regulations must also be taken into account.
10. Before starting work familiarize yourself with all installations and operating elements, as well as with their functions! Familiarization during operation is too late!
11. Caution must be exercised when working with a powder/air mixture! A powder/air mixture in the right concentration is flammable! Smoking is forbidden in the entire plant area!
12. As a general rule for all powder spraying installations, persons with pacemakers should never enter high voltage areas or areas with electromagnetic fields. Persons with pacemakers should not enter areas with powder spraying installations!



---

#### **WARNING!**

**We emphasize that the customer himself is responsible for the safe operation of equipment. ITW Gema is in no way responsible for any resulting damages!**

---

## **Safety conscious working**

Each person responsible for the assembly, start-up, operation, service and repair of powder spraying equipment must have read and understood the operating instructions and the "Safety regulations"-chapter. The operator must ensure that the user has had the appropriate training for powder spraying equipment and is aware of the possible sources of danger.

The control devices for the spray guns must only be set up and used in zone 22. The spray guns should be used in zone 21.

The powder spraying equipment should only be used by trained and authorized personnel. This applies to modifications to the electrical equipment, which should only be carried out by a specialist.

The operating instructions and the necessary closing down procedures must be followed before any work is carried out concerning the set-up, start-up, operation, modification, operating conditions, mode of operation, servicing, inspection or repairs.

The powder spray equipment can be turned off by using the main switch or failing that, the emergency shut-down. Individual components can be turned off during operation by using the appropriate switches.

## **Individual safety regulations for the operating firm and/or operating personnel**

1. Any operating method which will negatively influence the technical safety of the powder spraying equipment is to be avoided.
2. The operator should ensure that no non-authorized personnel works on the powder spraying equipment (e.g. this also includes using the equipment for non-conform work).

3. For dangerous materials, the employer has to provide an operating instructions manual, which specifies the dangers arising for humans and environment by handling dangerous materials, as well as the necessary preventive measures and behavior rules. The operating instructions manual has to be written in an understandable form and in the language of the persons employed, and has to be kept in a suitable place in the working area.
4. The operator is under obligation to check the powder spraying equipment at least once every shift for signs of external damage, defects or changes (including the operating characteristics) which could influence safety and to report them immediately.
5. The operator is obliged to check that the powder spraying equipment is only operated when in satisfactory condition.
6. As far as it is necessary, the operating firm must ensure that the operating personnel wear protective clothing (e.g. facemasks).
7. The operating firm must guarantee cleanliness and an overview of the workplace with suitable instructions and checks in and around the powder spraying equipment.
8. No safety devices should be dismantled or put out of operation. If the dismantling of a safety device for set-up, repair or servicing is necessary, reassembly of the safety devices must take place immediately after the maintenance or repair work is finished. The powder spraying device must be turned off while servicing is carried out. The operator must train and commit the responsible personnel to this.
9. Activities such as checking powder fluidization or checking the high-voltage spray gun etc. must be carried out with the powder spraying equipment switched on.

## **Notes on special types of hazard**

### ***Power***

It is necessary to refer once more to the danger of life from high-voltage current if the shut-down procedures are not observed. High voltage equipment must not be opened - the plug must first be taken out - otherwise there is danger of electric shock.

### ***Powder***

Powder/air mixtures can be ignited by sparks. There must be sufficient ventilation in the powder coating booth. Powder lying on the floor around the powder spraying device is a potentially dangerous source of slipping.

### ***Static charges***

Static charges can have the following consequences: Charges to people, electric shocks, sparking. Charging of objects must be avoided - see chapter "Grounding/Earthing".

### ***Grounding/Earthing***

All electricity conducting parts and machinery found in the workplace (according to DIN VDE 0745, part 102) must be earthed 1.5 meters either side and 2.5 meters around each booth opening. The earthing resistance should not exceed 1 M $\Omega$ . The resistance must be tested on a regular basis. The condition of the machinery surroundings as well as the sus-

pension gear must ensure that the machinery remains earthed. If the earthing of the machinery includes the suspension arrangements, then these must constantly be kept clean in order to guarantee the necessary conductivity. The appropriate measuring devices must be kept ready in the workplace in order to check the earthing.

### ***Compressed air***

When there are longer pauses or stand-still times between working, the powder spraying equipment should be drained of compressed air. There is a danger of injury, when pneumatic hoses are damaged, and from the uncontrolled release and improper use of compressed air.

### ***Crushing and cutting***

During operation, moving parts may automatically start to move in the operating area. It must be ensured that only instructed and trained personnel go near these parts. The operator should ensure that barriers comply with the local security regulations.

### ***Access under exceptional circumstances***

The operating firm must ensure that local conditions are met when repairs are made to the electronic parts or when the equipment is restarted so that there are additional measures such as barriers to prevent unauthorized access.

### ***Prohibition of unauthorized conversions and modifications to machines***

All unauthorized conversions and modifications to electrostatic spraying equipment are forbidden for safety reasons.

The powder spraying equipment should not be used if damaged, the faulty part must be immediately replaced or repaired. Only original ITW Gema replacement parts should be used. Damage caused by other parts is not covered by guarantee.

Repairs must only be carried out by specialists or in ITW Gema workshops. Unauthorized conversions and modifications may lead to injury or damage to machinery. The ITW Gema GmbH guarantee would no longer be valid.

## **Safety requirements for electrostatic powder coating**

1. This equipment is dangerous if the instructions in this operating manual are not followed.
2. All electrostatic conductive parts, in particular the machinery within 5 meters of the coating equipment, must be earthed.
3. The floor of the coating area must conduct electricity (normal concrete is generally conductive).
4. The operating personnel must wear electricity conducting footwear (e.g. leather soles).
5. The operating personnel should hold the gun with bare hands. If gloves are worn, these must also conduct electricity.
6. The supplied earthing cable (green/yellow) must be connected to the earthing screw of the electrostatic powder spraying hand appliance. The earthing cable must have a good metallic connec-

tion with the coating booth, the recovery unit and the conveyor chain and with the suspension arrangement of the objects.

7. The electricity and powder supply to the hand guns must be set up so that they are fully protected against heat and chemical damage.
8. The powder coating device may only be switched on once the booth has been started up. If the booth cuts out then the powder coating device must be switched off.
9. The earthing of all electricity conducting devices (e.g. hooks, conveyor chains) must be checked on a weekly basis. The earthing resistance should not exceed 1 MOhm.
10. The control device must be switched off if the hand gun is cleaned or the nozzle is changed.
11. When working with cleaning agents there may be a risk of hazardous fumes. The manufacturers instructions must be observed when using such cleaning agents.
12. The manufacturers instructions and the applicable environmental requirements must be observed when disposing of powder lacquer and cleaning agents.
13. If any part of the spray gun is damaged (broken parts, tears) or missing then it should not be used.
14. For your own safety, only use accessories and attachments listed in the operating instructions. The use of other parts can lead to risk of injury. Only original ITW Gema replacement parts should be used.
15. Repairs must only be carried out by specialists and under no circumstances should they be carried out in the operating area. The former protection must not be reduced.
16. Conditions leading to dangerous levels of dust concentration in the powder spraying booths or in the powder spraying areas must be avoided. There must be sufficient technical ventilation available, to prevent a dust concentration of more than 50% of the lower explosion limit (UEG) (UEG = max. permissible powder/air concentration). If the UEG is not known then a value of 10 g/m<sup>3</sup> should be used.

## A summary of the rules and regulations

The following is a list of relevant rules and regulations which are to be observed:

### ***Guidelines and regulations, German professional association***

BGV A1	General regulations
BGV A2	Electrical equipment and material
BGI 764	Electrostatic coating
BGR 132	Guidelines for the avoidance of the dangers of ignition due to electrostatic charging (Guideline "Static Electricity")
VDMA 24371	Guidelines for electrostatic coating with synthetic powder <sup>1)</sup> - Part 1 General requirements - Part 2 Examples of use

### **EN European standards**

RL94/9/EC	The approximation of the laws of the Member States relating to apparatus and safety systems for their intended use in potentially explosive atmospheres
EN 292-1 EN 292-2	Machine safety <sup>2)</sup>
EN 50 014 to EN 50 020, identical: DIN VDE 0170/0171	Electrical equipment for locations where there is danger of explosion <sup>3)</sup>
EN 50 050	Electrical apparatus for potentially explosive atmospheres - Electrostatic hand-held spraying equipment <sup>2)</sup>
EN 50 053, part 2	Requirements for the selection, installation and use of electrostatic spraying equipment for flammable materials - Hand-held electrostatic powder spray guns <sup>2)</sup>
EN 50 177	Stationary electrostatic spraying equipment for flammable coating powder <sup>2)</sup>
PR EN 12981	Coating plants - Spray booths for application of organic powder coating material - Safety requirements
EN 60 529, identical: DIN 40050	IP-Type protection: contact, foreign bodies and water protection for electrical equipment <sup>2)</sup>
EN 60 204 identical: DIN VDE 0113	VDE regulations for the setting up of high-voltage electrical machine tools and processing machines with nominal voltages up to 1000 V <sup>3)</sup>

### **VDE (Association of German Engineers) Regulations**

DIN VDE 0100	Regulations for setting-up high voltage equipment with nominal voltages up to 1000V <sup>4)</sup>
DIN VDE 0105 part 1 part 4	VDE regulations for the operation of high voltage equipment <sup>4)</sup> General regulations Supplementary definitions for stationary electrical spraying equipment
DIN VDE 0147 part 1	Setting up stationary electrostatic spraying equipment <sup>4)</sup>
DIN VDE 0165	Setting up electrical equipment in locations in areas with danger of explosion <sup>4)</sup>

**\*Sources:**

- <sup>1)</sup> Carl Heymanns Verlag KG, Luxemburger Strasse 449, 5000 Köln 41, or from the appropriate employers association
- <sup>2)</sup> Beuth Verlag GmbH, Burggrafenstrasse 4, 1000 Berlin 30
- <sup>3)</sup> General secretariat, Rue Bréderode 2, B-1000 Bruxelles, or the appropriate national committee
- <sup>4)</sup> VDE Verlag GmbH, Bismarckstrasse 33, 1000 Berlin 12

---

## Product specific security measures

- The installation work, to be done by the customer, must be carried out according to local regulations
- Before starting up the plant a check must be made to ensure that no foreign objects are in the booth or in the ducting (input and exhaust air)
- It must be observed, that all components are grounded according to the local regulations, before start-up

# About this manual

---

## General information

This operating manual contains all important information which you require for the working with the Magic Control CM-10 Plant control. It will safely guide you through the start-up process and give you references and tips for the optimal use of your new powder coating system.

Information about the function mode of the individual system components - booth, gun control unit, manual gun or powder injector - you will find in the corresponding enclosed documentations.

---

## Software version

This document describes the operation of the Magic Control CM-10 Plant control starting from the following software versions:

Software	Version
Galileo	CM-10_V54
MXPro	CM-10_V54



# Function description

---

## Field of application

The Magic Control CM-10 Plant control is built exclusively for electrostatic coating with organic powders. Any other use of the product will be considered as non intended use. The manufacturer is not responsible for any damage resulting from this; the risk is assumed by the user alone!

The Magic Control CM-10 Plant control is particularly suitable for the fully automatic coating of any kind of parts. Also in case of color changes, the Magic Control CM-10 Plant control ideally supports the operator. The Magic Control CM-10 Plant control is developed particularly for the operation in Magic booths.

---

## Magic Control CM-10 - overview

### Typical characteristics

Every OptiStar gun control unit, CR0x axis control unit, light grid, powder center and the digital in- and outputs communicate by CAN bus (field bus).

### Differences CM-10 / CM-20

System	Monitor	Flash Card	Num. of guns	Num. of stations	Axes per station	Axis type
CM-20 OptiControl	5.7"	1	24	2	2	from ZA04 from XT09
CM-10 Magic Control	12"	1 / 1	32+	4	2	from ZA04 from XT09



# Technical Data

---

## Magic Control CM-10 Plant control

### System

Magic Control CM-10	
Processor	RISC/1000 MIPS
Memory	64 MB
Remanent memory	32 kByte
2 <sup>nd</sup> Compact Flash slot	yes

### Electrical data

Magic Control CM-10	
Nominal voltage	24 VDC SELV, safety extra-low voltage
Voltage range	24 VDC according to DIN 19240 20.4 - 28.8 VDC (actual)
Reverse voltage protection	yes
Protection	yes (internal melting fuse)
Electrical insulation	no
Current consumption	max. 34 W/24 VDC
Switch-on current max.	3 A <sup>2</sup> s

### Display

Magic Control CM-10	
Technology	TFT color LCD
Resolution	800 x 600 pixel (SVGA)
Number of colors	65536
Display surface	246 x 185 mm
Operation	Infrared touch
Front screen	VSG laminated safety glass, anti reflex coated, scratch-proof

## Dimensions

Magic Control CM-10	
Mechanical dimensions	361 x 279 x 80 mm
Window	342 x 261 mm

## Connections

Magic Control CM-10	
Ethernet	1 x Fast Ethernet 100Base-TX Fast Ethernet 10Base-TX
CAN	1 x CAN, potential-free CiA, D-Sub 9pole
Comboard slot	2 x COM-TP
CompactFlash slot	2 x CompactFlash card, type I/II

## Environmental conditions

Magic Control CM-10	
Climate	0-50°C, 10-85% relative humidity, not condensing
Vibration / shock / drop test	Vibration - IEC68-2-6 Shock - IEC68-2-27 Drop test - IEC68-2-32

# Start-up

---

## General information

The Magic Control CM-10 Plant control is parameterized, configured and tested at the ITW Gema premises. This allows a faster start-up, because less parameters must be locally adjusted.

The application data in the laboratory report offer an additional assistance, because these can be used as basic adjustment for guns and reciprocators.

---

## General operating instructions

### Symbols



Key is not activated



Key is activated



Value input



Show help text

### *Violet color*



Gun not accessible by CAN bus



Axis not accessible by CAN bus

### *Yellow color*





Gun accessible by CAN bus





Axis accessible by CAN bus

**Green color**



-  Gun sprays powder
-  Gun sprays powder
-  Axis is moving

**Red color**

-  Gun error
-  Axis error

**Function keys**

**Open/close the cone caps**

1. Press the key  The cone caps open
2. Press the key  The cone caps close

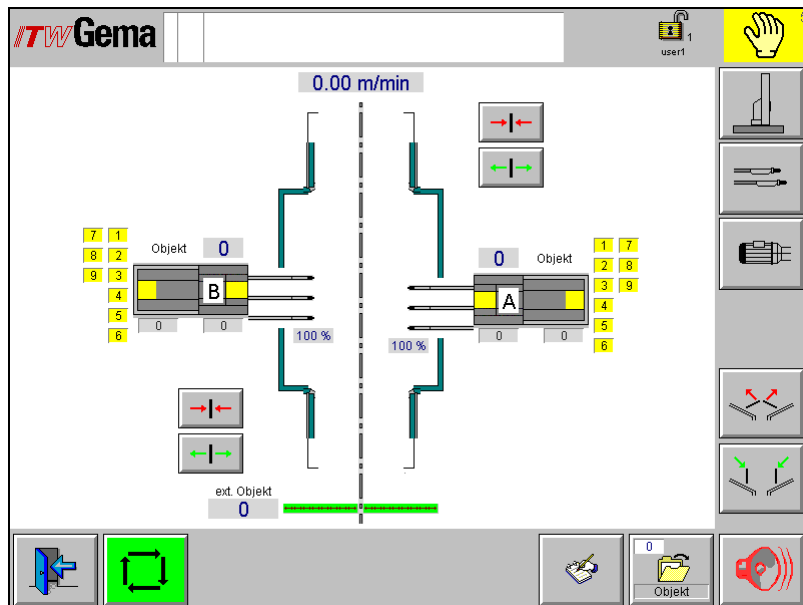

**Open/close the doors**

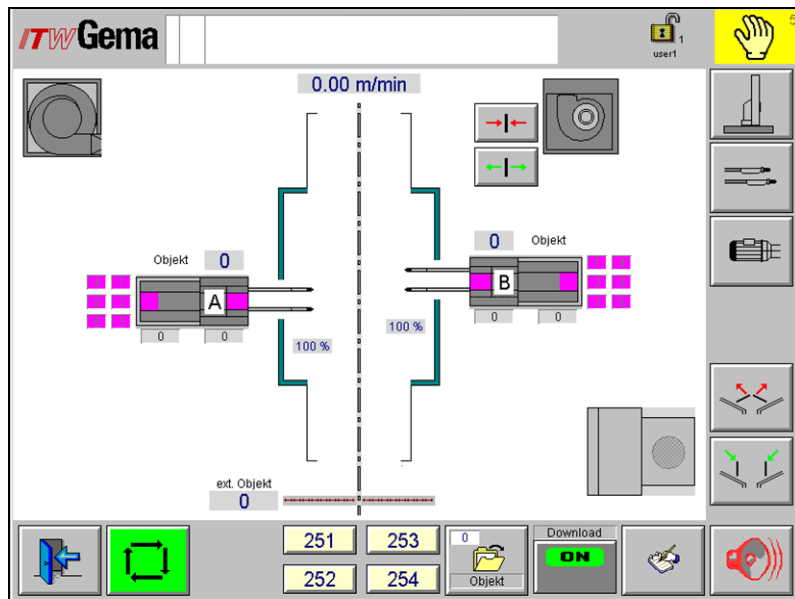

Open/close the doors



Open/close the doors

1. Press the key   
The doors close
2. Press the key   
The doors open



Error acknowledgement, alarm horn switches off



Menu step back



Parameterization of the equipment  
(see chapter "Parameterization")

### Light grid check

Press the key   
 The following page is displayed:

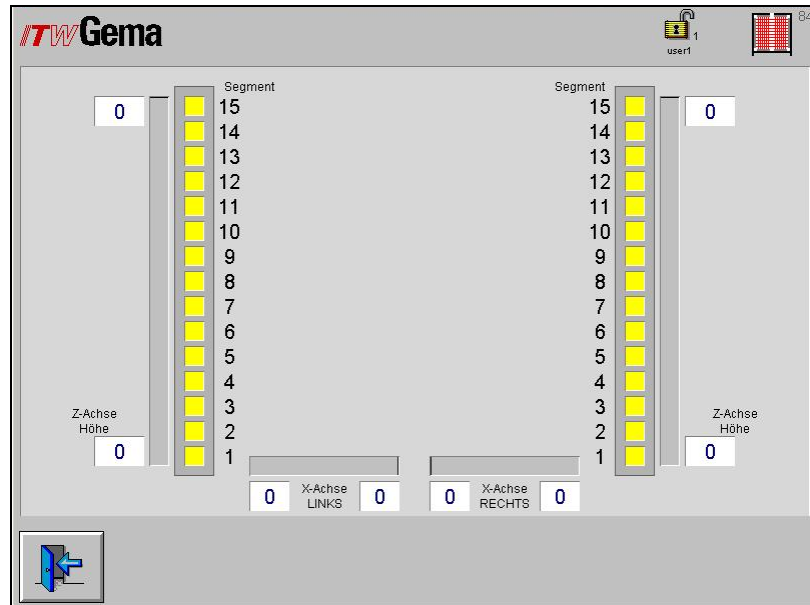

Light grid - information

- Display of the width on the left and on the right
- Display of the height (lowest interrupted light beam)
- Display of the segments

### Touch key fields

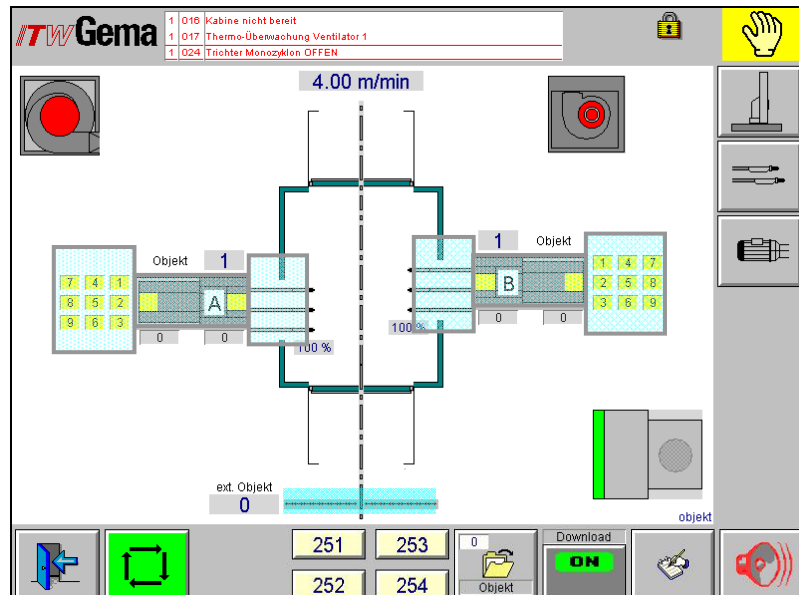

Touch key fields



Activated touch key fields

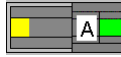

Edit axis values, select or deselect axes

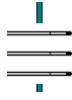

Edit gun values and select or deselect



Daily correction, select or deselect guns



Conveyor simulation, if conveyor does not run or CAN bus sensor is not installed or defective



Start and stop guns



Start and stop axes



Object data will be loaded directly in the gun/axes control unit



Object data will not be loaded

## Menu structure

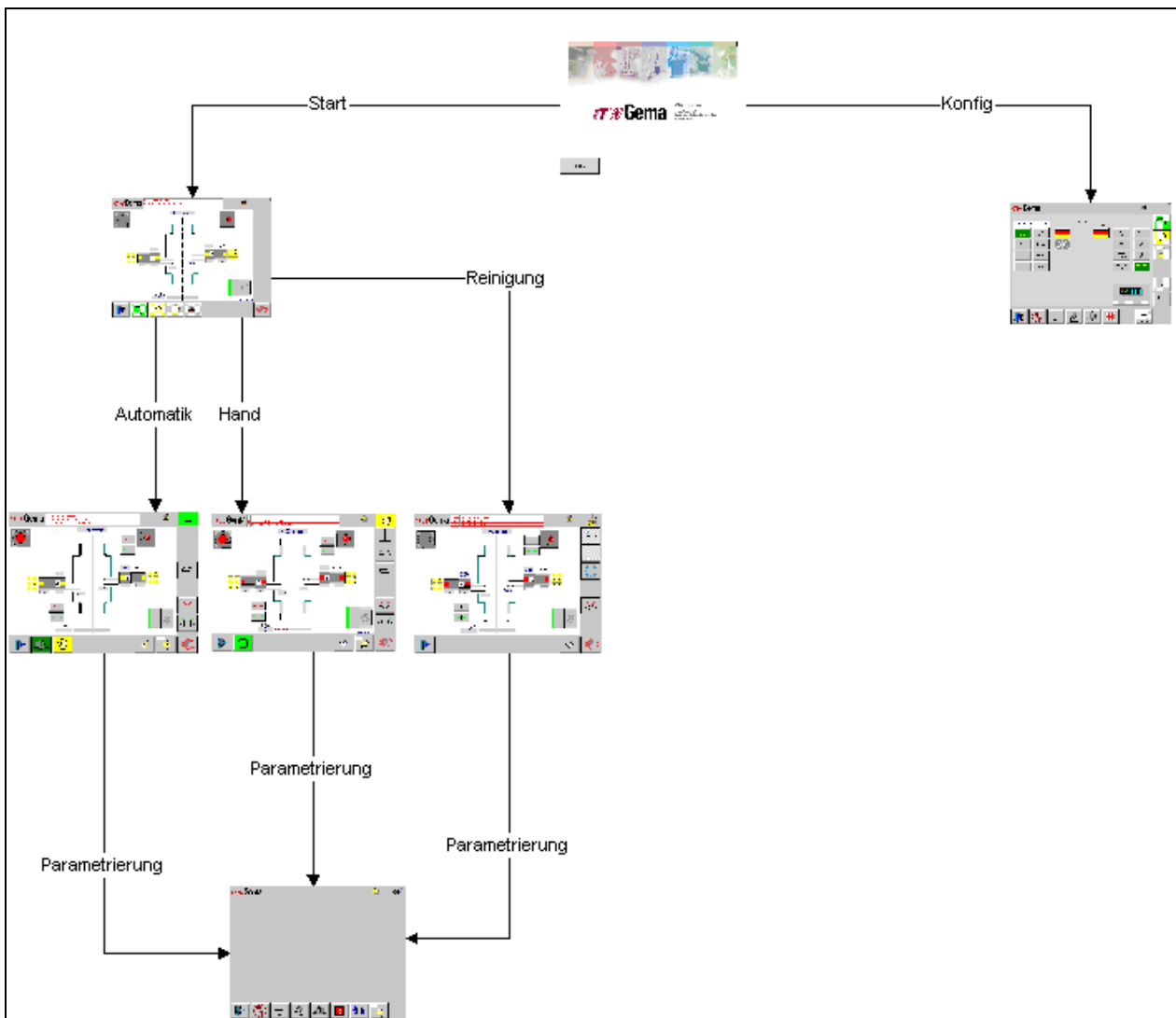

Menu structure

### Description of the german words:

Start = Start

Konfig = Configuration

Service = Service

Reinigung = Cleaning

Automatik = Automatic operating mode

Hand = Manual operating mode

Parametrierung = Parameterization

## Starting the equipment

### General information

1. Switch on main switch and the control voltage on the control cabinet.  
The Magic Control CM-10 Plant control starts the operating system, the PLC control and the operating software until the start page.



Start page

2. Press the start key  
The monitor switches to the main page:

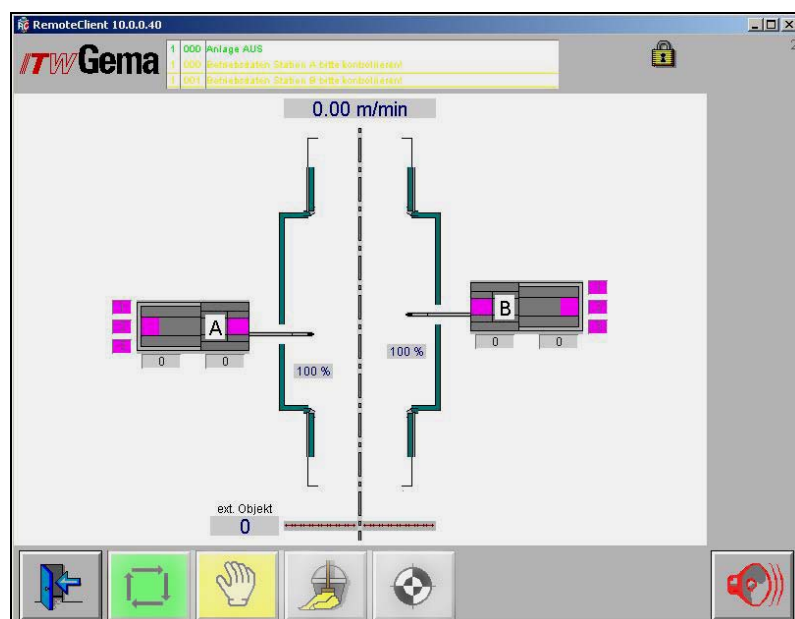

Main page not logged in

The operating of the equipment is locked (keys are not activated).



By logging in <sup>1</sup>, the keys are activated for operation.

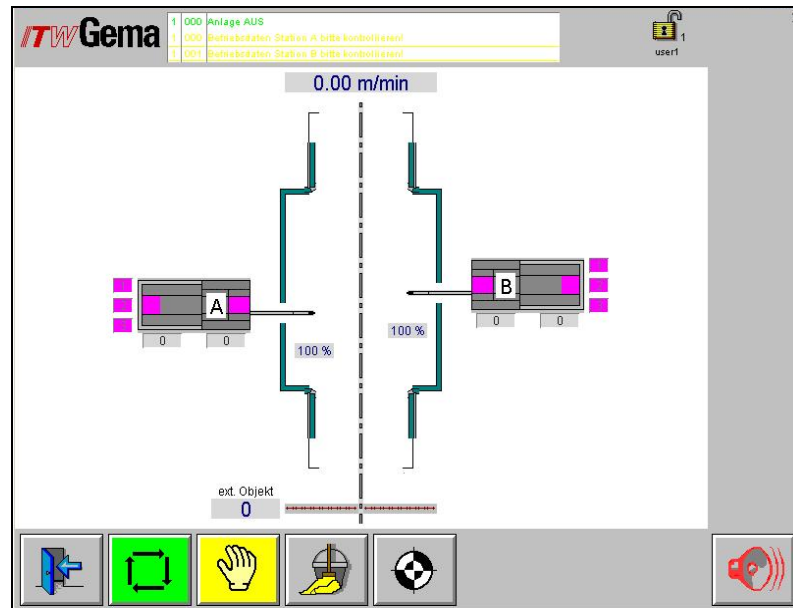

Main page logged in

3. Press the key  All axes move to their reference point position

4. Press the key, e.g.  The equipment switches to manual operating mode and the following page is displayed:

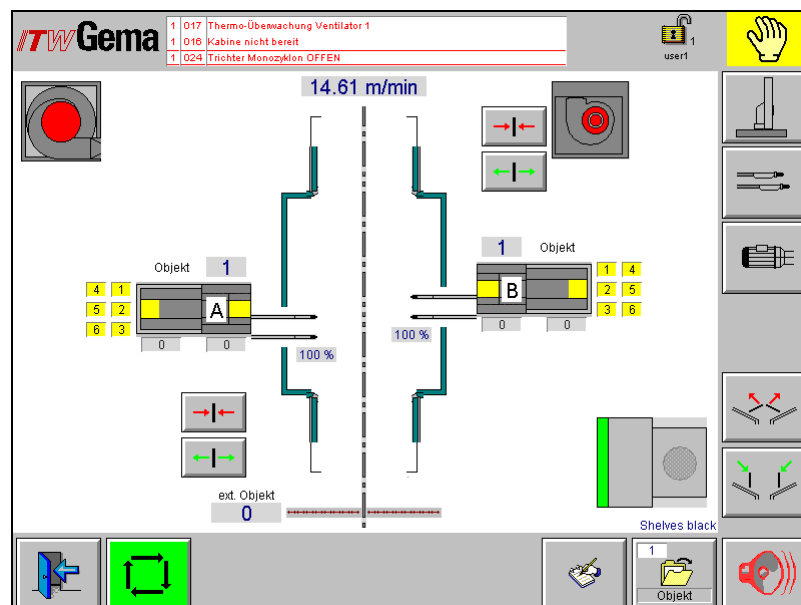

Manual operating mode

### Edit axis values, select or deselect



Press the key  
The following page is displayed:

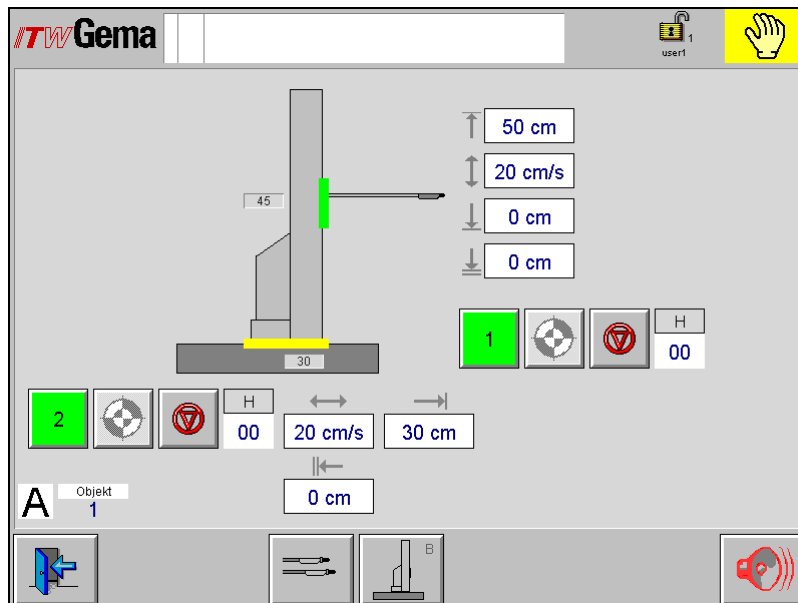

Edit and start axes

For details, see chapter "Operating modes"

### Edit gun values, select or deselect



Press the key  
The following page is displayed:

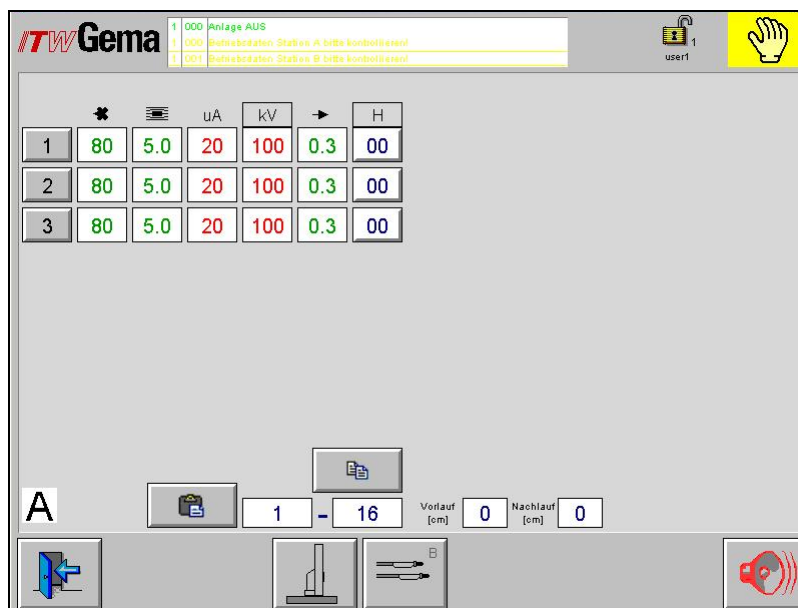

Edit gun values, select or deselect

For details, see chapter "Operating modes"



# Operating modes

## Overview

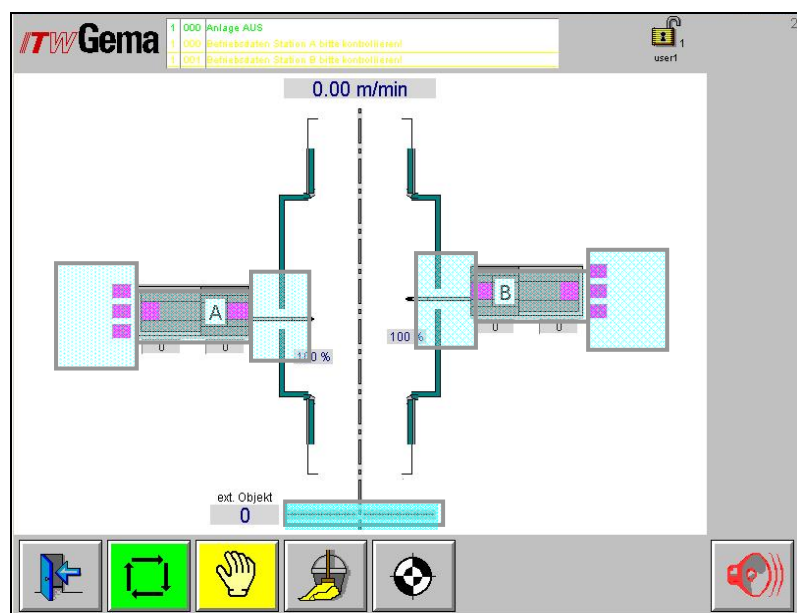

Operating modes



Select **Automatic** operating mode



Select **Manual** operating mode



Select **Cleaning** operating mode



Information **All axes are referenced**  
(after referencing, this key is not activated)

# Manual operating mode



Press the key  
The following page is displayed:

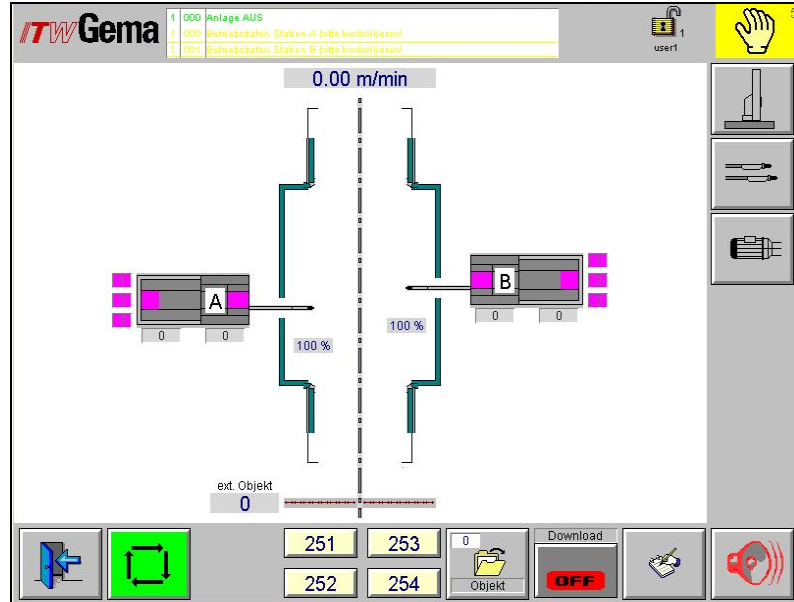

Manual operating mode

## Edit axis values, select or deselect axes

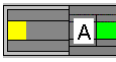

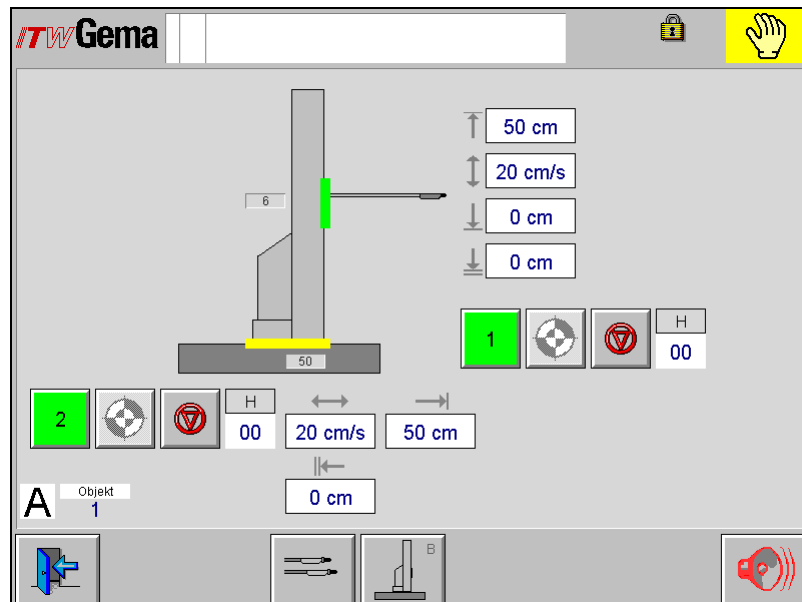

Press the key  
The following page is displayed:



Edit axis values

1. Press the key 

The key turns green  and the axis is selected.  
Only selected axes can be started
2. Press the key 

The axes start
3. Press the key 

The axes stop
4. The input fields allow the user to modify the position of the axes
5. By pressing the key , the error description is displayed

## Edit gun values and select or deselect

Press the key   
The following page is displayed:

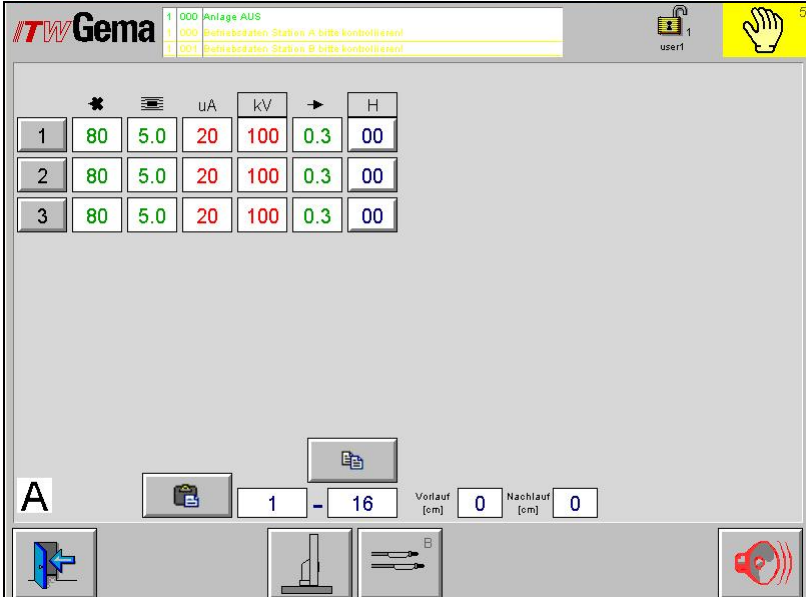



The screenshot shows the ITW Gema control interface. At the top, there is a status bar with the ITW Gema logo and a list of error messages. Below this is a table of gun parameters for three guns (1, 2, and 3). The table has columns for gun number, current (80), voltage (5.0), pressure (20), power (100), speed (0.3), and position (00). Below the table, there are control buttons for 'A', a gun icon, and a '1' button. To the right of these buttons are input fields for 'Vorlauf [cm]' (0) and 'Nachlauf [cm]' (0). At the bottom, there are several icons for navigation and control, including a blue arrow, a gun icon, a double arrow, and a red speaker icon.

	*	uA	kV	→	H	
1	80	5.0	20	100	0.3	00
2	80	5.0	20	100	0.3	00
3	80	5.0	20	100	0.3	00

*Edit gun values*

## Select or deselect guns

1. Press the key 

The key turns green  and the gun is selected
2. The input fields allow the user to modify the gun values
3. By pressing the key , the error description is displayed

### High voltage test

Press the key 

The key turns red 

1. The main solenoid valve will be closed
2. The axes will be switched off

### Copy gun data

1. Press the key  of the gun data, which shall be copied, the gun is selected

2. Press the key  The data is copied to the clipboard

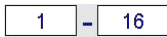
3. Press the key  and define where the data shall be copied

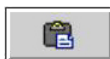
4. Press the key  The data will be paste



### Daily correction, select or deselect guns

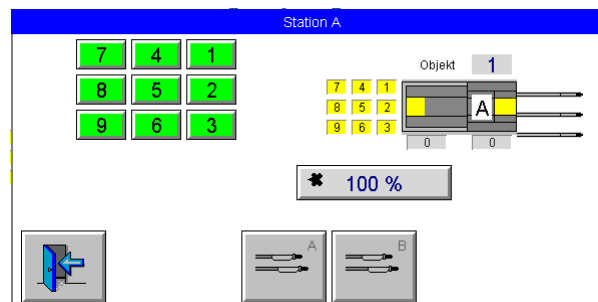

Press the key   
The following page is displayed:







1. Modify daily correction value for each station
2. Select or deselect guns

### Axes start independent of the conveyor

1. Press the key  The key turns green  and the activated conveyor is simulated

2. Press the key  The key turns green  and the reciprocators move, if the axes are selected

## Guns start independent of the conveyor

1. Press the key   
The key turns green  and the activated conveyor will be simulated
2. Press the key   
The key turns green  and the guns spray powder, if the guns are selected

## Automatic operation mode



Press the key  
The following page is displayed:

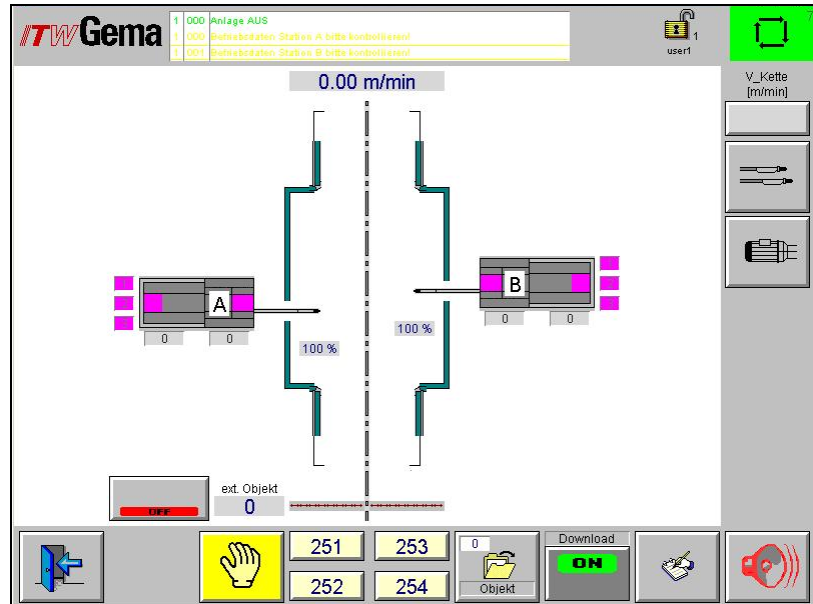

*Automatic operation mode*

- The guns and axes start automatically, based on the information from the light grid or the light barrier
- Object changes are carried out manually or automatically
- Daily correction of the powder output can be modified
- Guns can be selected or deselected
- Light grid can be checked

## Simulation of the CAN bus sensor



Press the key The key turns green



and the CAN bus sensor will be simulated.  
This means that the CAN bus sensor can be defective, or the conveyor is not ready for operation. Thanks to this simulation of the CAN bus sensor, coating is possible.

## Cleaning operation mode



Press the key

The following page is displayed:

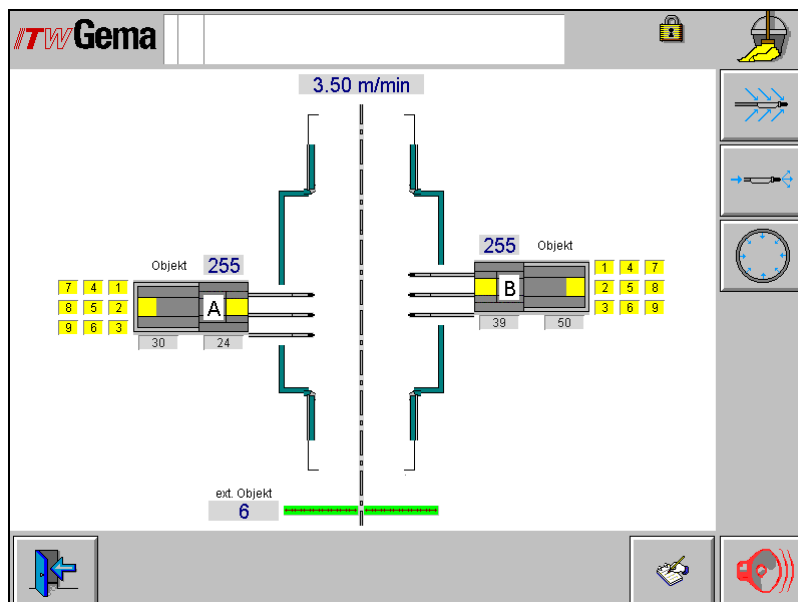

Cleaning operation mode

1. Close the doors

2. Press the key



The external gun cleaning will be started and the key turns green



The X axes travel into the booth to their final position.  
The Z axes travel to the adjusted cleaning position height.  
Once the X axes reached the position, the waiting period runs down.  
Subsequently, the X axes travel out of the booth and the outer cleaning valves are opened.

3. Press the key



The internal gun cleaning will be started and the key turns green



The X axes travel into the booth and the powder center receives the release to blow out the hoses and guns.

4. Press the key



The floor blow-off system switches on and the key turns green





# Parameterization

---

## Equipment parameterization

### Main page



Press the key

The following page is displayed:

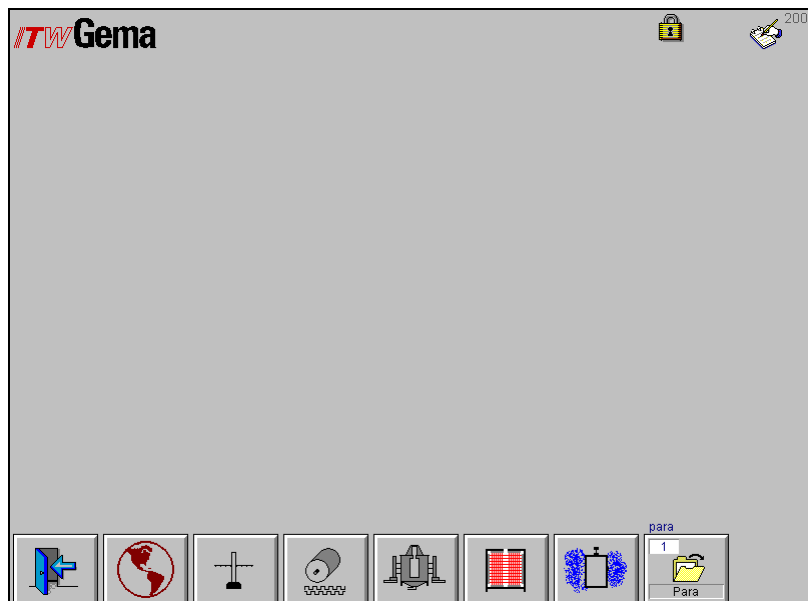

*Parameterization*

- General parameters
- Station parameters
- Calibration of the CAN bus sensor
- Booth parameters
- Light grid parameters for gun switch-off
- Object parameters for stroke switching

## General parameters



Press the key  
The following page is displayed:

Parameter ID	Parameter Name	Value
1.1.4	Minimale Taktzeit	2 s
1.1.7	Spülpuls	10 s
1.1.10	Verzögerung Meldungen	15 s
1.1.5	Verzögerung Achsen ein	1 s
1.1.8	Impulslänge Blinker ein	0.5 s
1.1.9	Impulslänge Blinker aus	0.5 s
1.1.6	Verzögerung Pistolen ein	1 s
<b>1.2 Pulver</b>		
1.2.1	Vorfluidisierung Gesamtzeit	50 s
1.2.2	Vorfluidisierung ein	1 s
1.2.3	Vorfluidisierung aus	1 s
1.2.4	Niveausonde 1	30 s
1.2.5	Pumpe 1 ein	30 s
1.2.6	Meldung 1	60 s
1.2.7	Niveausonde 2	10 s
1.2.8	Pumpe 2 ein	30 s
1.2.9	Meldung 2	60 s
1.2.10	Sieb ein 1	5 s
1.2.11	Sieb aus 1	30 s
1.2.12	Sieb ein 2	5 s
1.2.13	Sieb aus 2	30 s
1.2.14	Quetschventil Takt	7.0 s
1.2.15	Quetschventil öffnen	2.0 s
1.2.16	Quetschventil Förderluft	0.7 s

General parameters - overview

## General information

- Minimum pulse time,  
Time until **Conveyor does not run** - signal for switch-off the axes and guns
- Delay axes on,  
Time until **Conveyor runs** - signal for switch-on the axes
- Delay guns on,  
Time until **Conveyor runs** - signal active for switch-on the guns
- Rinsing pulse,  
Rinsing time of the powder hoses during the gap
- Pulse length warning light on  
Time until error light and alarm horn turn off
- Pulse length warning light off  
Time until error light and alarm horn turn on
- Delay of messages  
Time from the error occurrence to the display on the screen

## Powder

- Prefluidization total time
- Prefluidization on  
Switch-on duration
- Prefluidization off  
Switch-off duration
- Level sensor 1  
Time until fresh powder 1 will be requested

- Minimal duration until pump 1 switches on
- Message 1  
Time until the message **Lack of fresh powder** is displayed
- Level sensor 2  
Time until fresh powder 2 will be requested
- Minimal duration until pump 2 switches on
- Message 2  
Time until the message **Lack of fresh powder** is displayed

## Station parameters



Press the key

The following page is displayed:

The screenshot shows the ITW Gema parameterization interface. It features a grid for gun parameters (Pistole) and axis parameters (Achse). The gun parameters include starting points (Startpunkt [cm]), slot numbers (Schlitz), minimum powder output (FL\_min), and skewness (SKW%). The axis parameters include starting points (Startpunkt [cm]), pretravel (Vorlauf [cm]), and overtravel (Nachlauf [cm]). The interface also includes a 'Pistolenanordnung' field set to 42, and a 'Para' button at the bottom right.

Pistole	Startpunkt [cm]	Schlitz	FL_min	SKW%
1	100	1	1.8	100
2	100	1	1.8	100
3	100	2	1.8	100
4	100	2	1.8	100
5	100	2	1.8	100
6	100	3	1.8	100
7	100	3	1.8	100
8	100	2	1.8	100

Achse	Startpunkt [cm]	Vorlauf [cm]	Nachlauf [cm]
1	100	20	20
2	100	20	20

### Starting points

Adjust starting points, pretravel and overtravel:

1. Modify the starting points for each gun
2. Enter the slot number
3. Adjust pretravel and overtravel of the guns
4. Modify the starting points for each axis
5. Adjust pretravel and overtravel for each axis
6. Powder hose length correction:  
Determine and enter the minimum powder output (FL\_min) and correction value (SKW%) in accordance to the gun control unit operating manual

## Calibration of the CAN bus sensor



Press the key  
The following page is displayed:

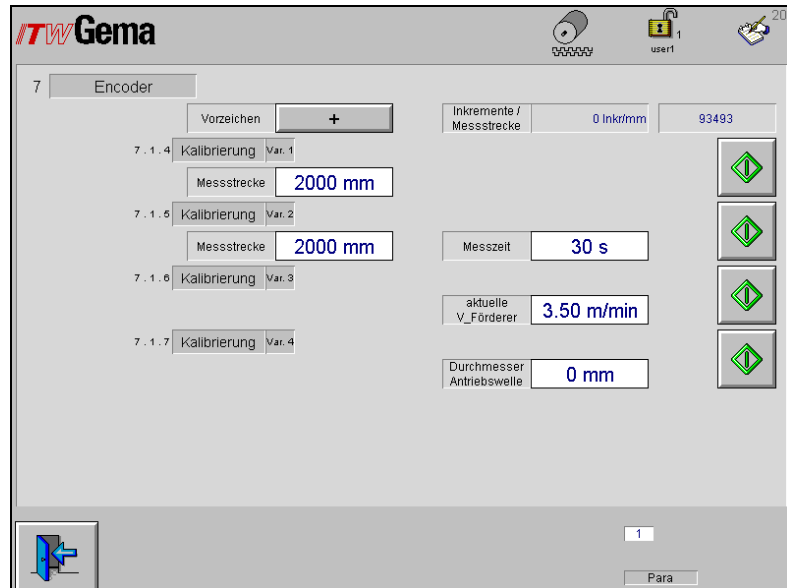

*Calibration of the CAN bus sensor*

Four calibration options are available:

1. Calibrating a measuring section of 2 meters by **Start/stop** key
2. Calibrating a measuring section of 2 meters with the indication of the time needed for it, by pressing the **Start** key
3. Calibrating by indicating the current conveying speed and by pressing the **Start** key
4. Calibrating by indicating the drive shaft diameter and by pressing the **Start** key

## Booth parameters



Press the key

The following page is displayed:

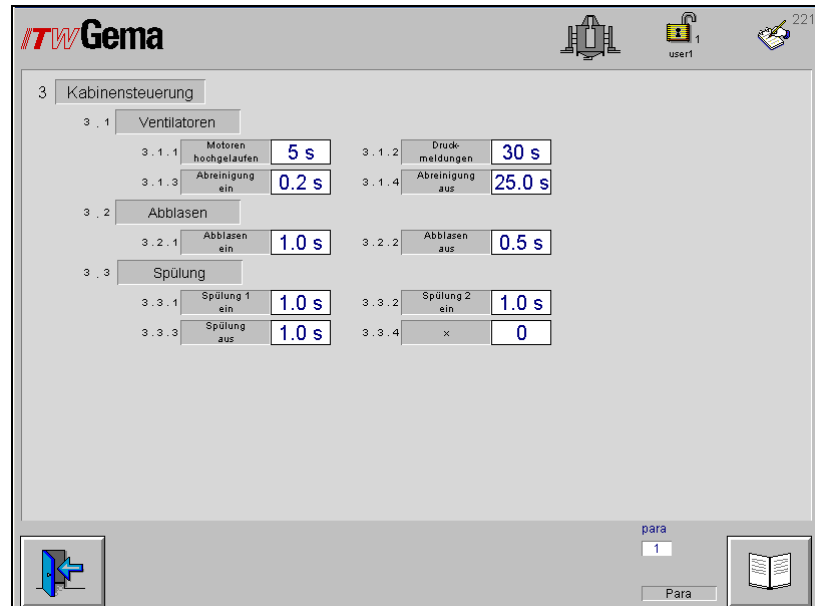

Booth parameters

### Fans

- Time until the motors are started and the booth is ready for operation
- Time for the delay of the pressure messages of the fans
- Time of the cleaning impulse of the filter plates
- Pause time until the next cleaning impulse

### Blow-off cleaning

- Time of the outer cleaning impulse
- Pause time until the next outer cleaning impulse

### Rinsing

- Time of floor blow-off system switch-on (Rinsing 1)
- Time of floor blow-off system channel switch-on (Rinsing 2)
- Time of blow-off switch-off (Rinsing off)
- Number of repetitions

## Light grid evaluation for gun switch-off



Press the key

The following page is displayed:

Pistolengruppe	Segment	Pistolengruppe	Segment
1	0000001111111111	9	1111111111111111
2	1111111111111111	10	1111111111111111
3	1111111111111111	11	1111111111111111
4	1111111111111111	12	1111111111111111
5	1111111111111111	13	1111111111111111
6	1111111111111111	14	1111111111111111
7	1111111111111111	15	1111111111111111
8	1111111111111111	Maskierung	1111111111111111

Lichtgitterabstand: 20 cm  
 Sprühabstand: 20 cm

1  
Para

*Light grid evaluation for gun shutdown*

- Highest gun row corresponds to the first gun group
- Highest segment information of the light grid is segment 15
- Enter in which active segment the guns should switch on
- The hiding option hides general information
- Spraying distance is the shortest spraying distance needed on the equipment

## Light grid evaluation for stroke switching and gradually adaptation of sinus

### Option 1



Press the key

The following page is displayed:

Segment	Objekt	Segment	Objekt
1	0	9	0
2	0	10	0
3	0	11	0
4	0	12	0
5	0	13	0
6	0	14	0
7	0	15	0
8	0		

Kontrolldistanz: 1000 cm  
 Lücke: 200 cm  
 Ausblendfenster: 0 cm  
 Spüldistanz: Startpunkt [cm] 2, Nachlauf [cm] 20  
 Objekt: Vorlauf [cm] 30, Nachlauf [cm] 30









para: 1  
 Para

Light grid evaluation for stroke switching

- Enter the object number, in which segment which object should be loaded
- Control distance  
Serves to check the pollution or functionality of the light grid or the light barrier
- Gap  
If there is no object detected during this distance, the X axes move out of the booth and the outer cleaning valves blow off the guns
- Window hiding feature  
Hooks or hangers can be hidden
- Rinsing distance  
Cleaning of the hangers with start point and overtravel
- Object pretravel and overtravel

**Option 2**

*Gradually adaptation of sinus and conveying speed*





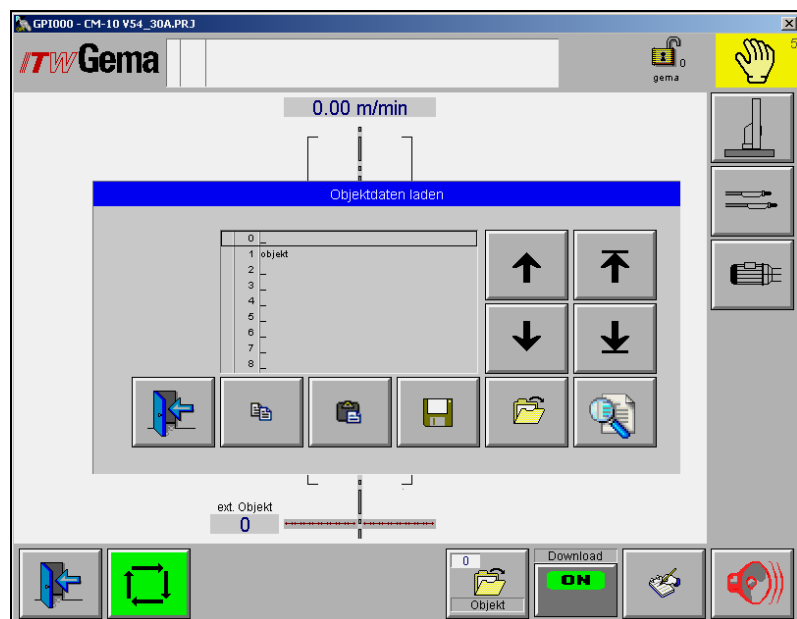

- Definition of an upper reversing point  for each highest segment and a lower reversing point  for each lowest segment
- 2.1**
- Enter a stroke speed  for each individual stroke of 1-15 segments (defined by the upper and lower reversing point) by the sinus program
  - Enter a powder adaptation  % for each stroke
  - Enter an air adaptation  % for each stroke
- 2.2**
- Definition of the speed for 8 chain stages **m/min**
  - Enter a stroke speed adaptation , a powder adaptation  % and an air adaptation  % for each chain stage

# Object data administration

## Load and save object data



Load object data





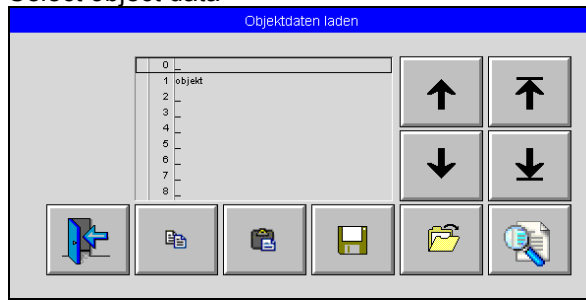

	Line up
	Line down
	Page up
	Page down
	Save object data
	Data search by name entry

## Copy and insert object data

1. Select object data



*Load object data*

2. Press the key  Object data is loaded
3. Press the key  Object data is copied to the clipboard
4. With help of the arrow keys   select the object to which the data shall be copied from the clipboard
5. Press the key  Object data is loaded
6. Press the key  Object data is copied to the current object
7. Press the key  Object data is saved

## Name object data

By pressing the table field, a keyboard is displayed with which the data set can be named.

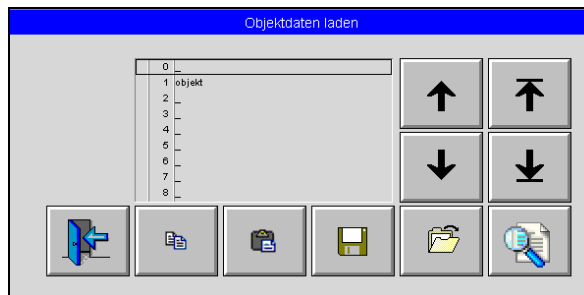

*Name object data*

# Error display / diagnostics

## Error display main page

ID	Description	Timestamp
1 049	Sicherung Pistolen NOK	16.07.07 16:24:31
1 050	Sicherung Achsen NOK	16.07.07 16:24:31
1 052	Druckluft NOK	16.07.07 16:24:31
1 000	Anlage AUS	16.07.07 16:24:31
1 000	Betriebsdaten Station A bitte kontrollieren!	17.07.07 09:48:39
1 001	Betriebsdaten Station B bitte kontrollieren!	17.07.07 09:48:39
1 007	Pause Ventilator 1, bitte warten!	17.07.07 10:50:54
1 008	Pause Ventilator 2, bitte warten!	17.07.07 10:50:54

Control panel buttons: Kette, A, B, Mode, Objekt, HISTORY, HISTORY, [Speaker icon]

Error display

	Line up
	Line down
	Go to first entry
	Go to last entry
	Display error history
	Delete error history



Display of the active CAN bus devices



Acknowledge error

## Activated CAN bus devices



Press the key  
The following page is displayed:

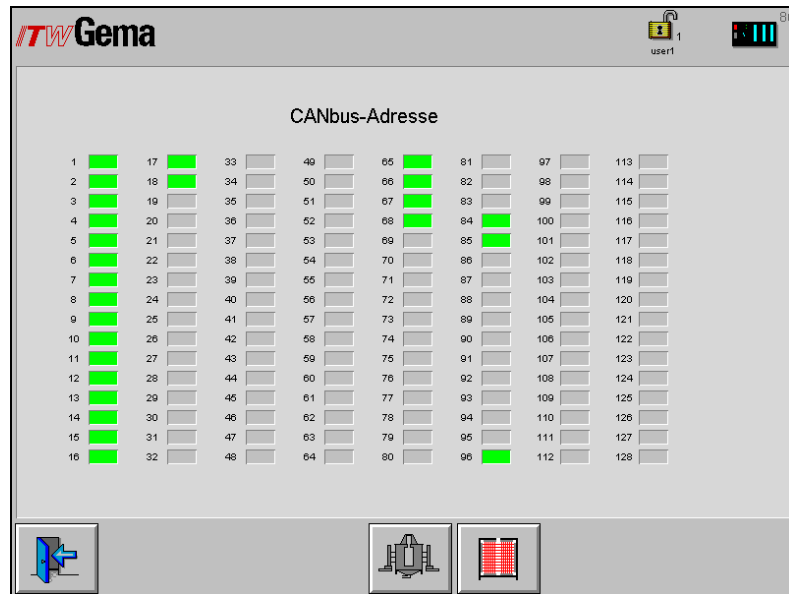

Activated CAN bus devices

Fields colored in green show active CAN bus devices.

Device	Decimal address	Hexadecimal address
Powder guns	1 - 64	1 - 3F
Axes	65 - 80	41 - 50
Powder center CPU	82	52
Booth knot	84	54
Light grid knot	85	55
Sensor	96	60
Powder center panel	97	61
CEDES light grid	100	64

# Check digital inputs, set and delete outputs



Press the key  
The following page is displayed:

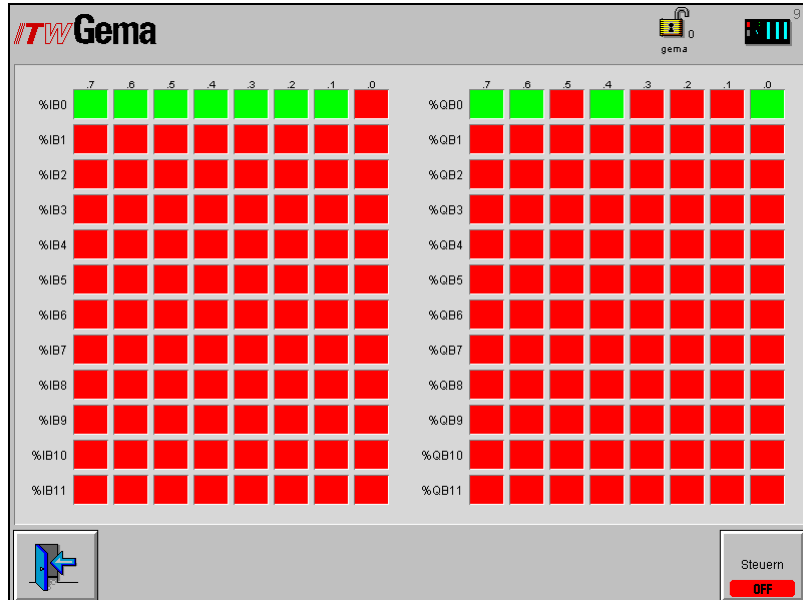

Digital inputs and outputs



Press the key  
The following page is displayed:

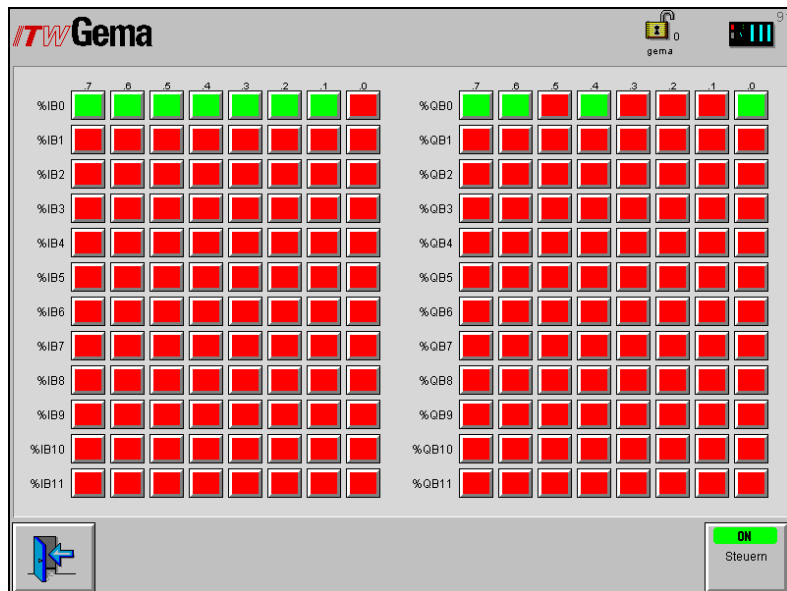

Set and delete digital outputs

Press the key

The key turns green and the output is set.

## Operating hours administration



Press the key  
The following page is displayed:

	Ventilator	Achse	Pistole
1	0.0 [h]	11.0 [h]	2.0 [h]
		21.0 [h]	3.0 [h]
			4.0 [h]
	0 [m]	0 x	0 %
	0.0 [min]	52.7 [min]	
	0.0 [min]	0.2 [min]	0 x
			52.4 [min]

*Operating hours administration A*

- Display of the operating hours of each operating mode
- Display of the cleaning cycles
- Display of the operating hours of the fan/the conveyor
- Display of the operating hours of the axes
- Display of the operating hours of the guns



Press the key   
The following page is displayed:

	Achse	Pistole
1	0.0 [h]	5.0 [h]
2	0.0 [h]	6.0 [h]
		7.0 [h]

Operating hours administration B

- Display of the operating hours of the axes
- Display of the operating hours of the guns

Press the key   
The following page is displayed:

Sollwert [h]	Istwert [h]
500.0 [h]	7.0 [h]
	
	Total [h]
	0.0 [h]

Operating hours

1. Set the preset value  
If the actual value reaches the preset value, an error message will be displayed



2. Press the   
The actual value is added to the total value and set to zero



# User levels and access

---

## Log-in

1. Press the key  and a dialogue window will pop up
2. Enter name (USER) and password (e.g. user3 and u3)
3. If the name and password correspond, the system acknowledges



it with the symbol

4. If the key is pressed again, the system logs out and the user panel is locked
5. The set-up of new user profiles is done on the first page with 

---

## User level 0



- The panel can be used without any limitation
- The level is reserved for specialized Gema staff
- After 3 minutes, the system logs out automatically

---

## User level 1



- No configuration possible
- Plant parameters and object-related data (gun and axis data) can be modified
- After 30 minutes, the system logs out automatically

---

## User level 2



- No configuration and parameterization possible
- Plant parameters can not be modified
- Object-related data (gun and axis data) can be modified
- No automatic log-out

---

## User level 3



- No configuration and parameterization possible in this level
- The user can only activate existing object data, modify the daily correction and deselect guns
- If no user is logged in, the user panel is locked
- No automatic log-out

---

## No user level



- Logged out status

# Plant configuration

## General information



*Start page*

# Settings

## Overview

Press the key **Konfig**  
The following page is displayed:

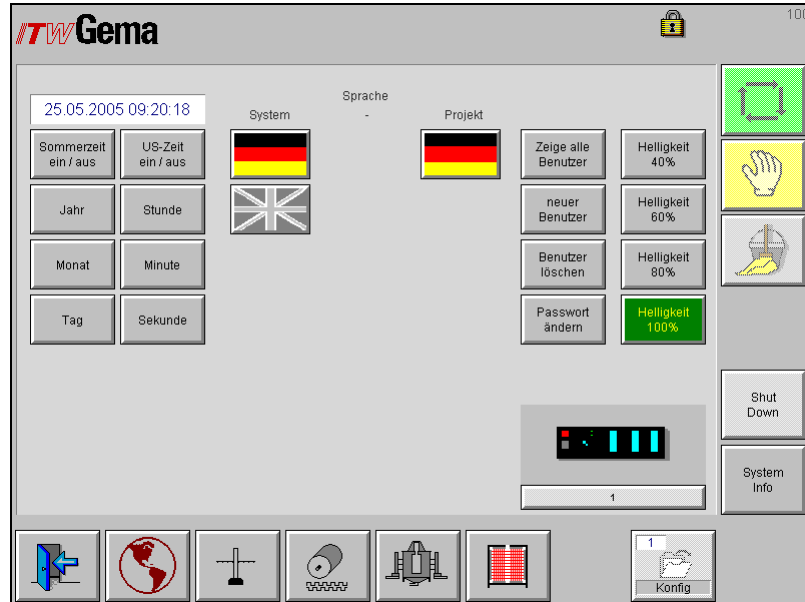

*Configuration main page*

- Adjust the time
- Select the system language german/english  
Important - restart the Magic Control CM-10 Plant control unit
- Select the project language  
The following languages are available:



*Languages*

- Show all users
- Define new users
- Delete users
- Change password of current user
- Adjust brightness
- End visualization
- System information

- Limitation of the available operating modes
- Select the input/output assignment option
- Load or copy the configuration  
Backup of the configuration is saved under "99 Backup"

## Keys



General configuration parameters of the plant



Station definition, axes and guns with system parameters



Release the four available calibration options of the CAN bus sensor



Booth definition



Set the object recognition type



# Spare parts list

---

## Ordering spare parts

When ordering spare parts for powder coating equipment, please indicate the following specifications:

- Type and serial number of your powder coating equipment
- Order number, quantity and description of each spare part

**Example:**

- **Type** Magic Control CM-10 Plant control  
**Serial no.** 1234 5678
- **Order no.** 203 386, 1 piece, clamp - Ø 18/15 mm

When ordering cable or hose material, the required length must also be given. The spare part numbers of this yard/meter ware is always marked with an \*.

The wear parts are always marked with a #.

All dimensions of plastic hoses are specified with the external and internal diameter:

**Example:**

Ø 8/6 mm, 8 mm outside diameter (o/d) / 6 mm inside diameter (i/d)



---

**WARNING!**

**Only original ITW Gema spare parts should be used as the explosion protection will also be preserved that way. The use of spare parts from other manufacturers will invalidate the ITW Gema guarantee conditions!**

---

---

## Magic Control CM-10 - complete

1	Micro Touch Panel MC 12" - complete (without pos. 2)	268 992
2	Compact Flash Card 32 MB	269 018

---



*Magic Control CM-10*

