

---

Operating instructions and spare parts list

# Powder coating equipment

## OptiFlex BN

### (for Boron Nitride)

This equipment was developed for use with electrically non-conducting powders. The use of electrically conducting powders (like metallic or graphite powders) can cause a permanent decrease of functioning.

**TW**  
**Gema**



**Documentation OptiFlex BN Powder coating equipment**

© Copyright 2005 ITW Gema AG

All rights reserved.

This publication is protected by copyright. Unauthorized copying is prohibited by law. No part of this publication may be reproduced, photocopied, translated, stored on a retrieval system or transmitted in any form or by any means for any purpose, neither as a whole nor partially, without the express written consent of ITW Gema AG.

OptiTronic, OptiGun, EasyTronic, OptiSelect, OptiFlow and SuperCorona are registered trademarks of ITW Gema AG.

OptiMatic, OptiMove, OptiMaster, OptiPlus, MultiTronic and Gematic are trademarks of ITW Gema AG.

All other product names are trademarks or registered trademarks of their respective holders.

Reference is made in this manual to different trademarks or registered trademarks. Such references do not mean that the manufacturers concerned approve of or are bound in any form by this manual. We have endeavored to retain the preferred spelling of the trademarks, and registered trademarks of the copyright holders.

To the best of our knowledge and belief, the information contained in this publication was correct and valid on the date of issue. ITW Gema AG makes no representations or warranties with respect to the contents or use of this publication, and reserves the right to revise this publication and make changes to its content without prior notice.

**Printed in Switzerland**

ITW Gema AG  
Mövenstrasse 17  
9015 St.Gallen  
Switzerland

Phone: +41-71-313 83 00  
Fax.: +41-71-313 83 83

E-Mail: [info@itwgema.ch](mailto:info@itwgema.ch)  
Homepage: [www.itwgema.ch](http://www.itwgema.ch)

# Table of contents

<b>General safety regulations</b>	<b>3</b>
Safety symbols (pictograms).....	3
Conformity of use.....	3
Technical safety regulations for stationary electrostatic powder spraying equipment .....	4
General information .....	4
Safety conscious working .....	5
Individual safety regulations for the operating firm and/or operating personnel .....	6
Notes on special types of hazard.....	6
Safety requirements for electrostatic powder coating.....	8
A summary of the rules and regulations .....	9
Product specific security measures .....	10
<b>About this manual</b>	<b>11</b>
General information .....	11
<b>Function description</b>	<b>13</b>
Field of application .....	13
Typical characteristics.....	13
OptiFlex BN Powder coating equipment.....	14
Structure.....	14
OptiStar control unit .....	14
OptiFlow injector .....	14
Powder guns and powder hoses .....	15
Stirrer hopper .....	16
Scope of delivery .....	17
OptiFlex 1-BN.....	17
Additional supply for OptiFlex 2-BN.....	17
<b>Technical data</b>	<b>19</b>
OptiFlex BN Powder coating equipment.....	19
Electrical data .....	19
Pneumatic data .....	19
Connectable guns .....	20
Dimensions .....	20
<b>Start-up and operation</b>	<b>21</b>
Connecting guide .....	21
Adapter for external triggered powder guns (Boron Nitride adapter).....	22
Preparation for start-up .....	23
Fill the stirrer recipient with powder .....	23
Switch on the booth .....	23
Start-up .....	23
Stirrer .....	23
Switch on the control unit.....	23

<b>Color change</b>	<b>25</b>
General information .....	25
<b>Maintenance and cleaning</b>	<b>27</b>
Daily maintenance .....	27
Weekly maintenance .....	27
If in disuse for several days .....	27
Powder hose rinsing .....	27
Cleaning .....	28
Cleaning the OptiSelect manual powder gun .....	28
Maintenance and cleaning of the filter unit .....	28
Replacing the filter element .....	28
<b>Troubleshooting</b>	<b>29</b>
General information .....	29
<b>Schematic diagrams</b>	<b>31</b>
OptiFlex BN - block diagram .....	31
OptiFlex BN Powder coating equipment - pneumatic diagram .....	32
<b>Spare parts list</b>	<b>33</b>
Ordering spare parts .....	33
OptiFlex BN - spare parts list .....	34
OptiFlex BN - spare parts list .....	35
OptiFlex BN - stirrer hopper .....	36
OptiFlex BN - stirrer hopper .....	37
OptiFlex BN - stirrer drive unit .....	38
OptiFlex BN - stirrer drive unit .....	39
OptiFlex BN - filter unit .....	40

# General safety regulations

This chapter sets out the fundamental safety regulations that must be followed by the user and third parties using the OptiFlex BN Powder coating equipment.

These safety regulations must be read and understood before the OptiFlex BN Powder coating equipment is used.

---

## Safety symbols (pictograms)

The following warnings with their meanings can be found in the ITW Gema operating instructions. The general safety precautions must also be followed as well as the regulations in the operating instructions.

**DANGER!**

danger due to live electricity or moving parts. Possible consequences: Death or serious injury

**WARNING!**

Improper use of the equipment could damage the machine or cause it to malfunction. Possible consequences: minor injuries or damage to equipment

**INFORMATION!**

useful tips and other information

---

## Conformity of use

1. The OptiFlex BN Powder coating equipment is built to the latest specification and conforms to the recognized technical safety regulations and is designed for the normal application of powder coating.
2. Any other use is considered as non-conform. The manufacturer is not responsible for any damage resulting from this - the risk for this is assumed by the user alone! If the OptiFlex BN Powder coating equipment is to be used for other purposes or other substances outside of our guidelines then ITW Gema AG should be consulted.

3. Observance of the operating, service and maintenance instructions specified by the manufacturer is also part of the conformity of use. The OptiFlex BN Powder coating equipment should only be used, maintained and started up by trained personnel, who are informed about and are familiar with the possible hazards involved.
4. Start-up (i.e. the execution of a particular operation) is forbidden until it has been established that the OptiFlex BN Powder coating equipment has been set up and wired according to the guidelines for machinery (98/37 EG). EN 60204-1 (machine safety) must also be observed.
5. Unauthorized modifications to powder spraying equipment exempts the manufacturer from any liability from resulting damage.
6. The relevant accident prevention regulations, as well as other generally recognized safety regulations, occupational health and structural regulations are to be observed.
7. Furthermore the country-specific safety regulations must be observed.

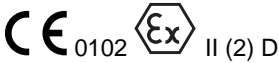
Explosion protection	Protection type	Temperature class
	IP54	T6 (zone 21) T4 (zone 22)

## Technical safety regulations for stationary electrostatic powder spraying equipment

### General information

The powder spraying equipment of ITW Gema is designed with safety in mind and is built according to the latest technological specifications. This equipment can be dangerous if it is not used for its specified purpose. Consequently it should be noted, that there exists a danger to life and limb of the user or third party, a danger of damage to the equipment and other machinery belonging to the user and a hazard to the efficient operation of the equipment.

1. The powder spraying equipment should only be started up and used once the operating instructions have been carefully studied. Incorrect operation of the control unit can lead to accidents, malfunctions or damage to the control itself or to the plant.
2. Before every start-up check the equipment for operational safety (regular servicing is essential)!
3. Safety regulations BGI 764 and VDE regulations DIN VDE 0147, Part 1, must be observed for safe operation.
4. Please observe the local safety regulations!
5. The plug must be disconnected before the machine is opened for repair.
6. The plug and socket connections between the powder spraying equipment and the mains network should only be removed when the power supply is switched off.

7. The connecting cable between the controlling device and the spray gun must be set up so that it cannot be damaged during operation. Please observe the local safety regulations!
8. Only original ITW-Gema spare parts should be used, because the explosion protection will also be preserved that way. Damage caused by other parts is not covered by guarantee.
9. If ITW-Gema powder spraying equipment is used in conjunction with machinery from other manufacturers then their safety regulations must also be taken into account.
10. Before starting work familiarize yourself with all installations and operating elements, as well as with their functions! Familiarization during operation is too late!
11. Caution must be exercised when working with a powder/air mixture! A powder/air mixture in the right concentration is flammable! Smoking is forbidden in the entire plant area!
12. As a general rule for all powder spraying installations, persons with pacemakers should never enter high voltage areas or areas with electromagnetic fields. Persons with pacemakers should not enter areas with powder spraying installations!



---

**WARNING!**

**We alert that the customer himself is responsible for the safe operation of equipment. ITW Gema AG is in no way responsible for any resulting damages!**

---

## Safety conscious working

Each person responsible for the assembly, start-up, operation, service and repair of powder spraying equipment must have read and understood the operating instructions and the "Safety regulations"-chapter. The operator must ensure that the user has had the appropriate training for powder spraying equipment and is aware of the possible sources of danger.

The control devices for the spray guns must only be set up and used in zone 22. Spray guns are admitted in zone 21.

The powder spraying equipment should only be used by trained and authorized personnel. This applies to modifications to the electrical equipment, which should only be carried out by a specialist.

The operating instructions and the necessary closing down procedures must be followed before any work is carried out concerning the set-up, start-up, operation, modification, operating conditions, mode of operation, servicing, inspection or repairs.

The powder spray equipment can be turned off by using the main switch or failing that, the emergency shutdown. Individual components can be turned off during operation by using the appropriate switches.

## Individual safety regulations for the operating firm and/or operating personnel

1. Any operating method, which will negatively influence the technical safety of the spraying equipment, is to be avoided.
2. The operator has to ensure that no non-authorized persons work on the powder spraying equipment (e.g. this also includes using the equipment for non-conform work).
3. For dangerous materials, the employer has to provide an operating instructions manual for specifying the dangers arising for humans and environment by handling dangerous materials, as well as the necessary preventive measures and behavior rules. The operating instructions manual has to be written in an understandable form and in the language of the persons employed, and has to be announced in a suitable place in the working area.
4. The operator is under obligation to check the powder spraying equipment at least once every shift for signs of external damage, defects or changes (including the operating characteristics) which could influence safety and to report them immediately.
5. The operating enterprise has to ensure that GEMA electrostatic spraying equipment is only operated in perfect condition.
6. As far as it is necessary, the operating firm must ensure that the operating personnel wear protective clothing (e.g. facemasks).
7. The operating firm must guarantee cleanliness and an overview of the workplace with suitable instructions and checks in and around the powder spraying equipment.
8. No safety devices should be dismantled or put out of operation. If the dismantling of a safety device for set-up, repair or servicing is necessary, reassembly of the safety devices must take place immediately after the maintenance or repair work is finished. All maintenance activities must be executed when the powder spraying mechanism is switched off. The operator must train and commit the responsible personnel to this.
9. Activities, such as checking powder fluidization or checking the high voltage spray gun etc., must be carried out with the powder spraying equipment switched on.

## Notes on special types of hazard

### ***Power/tension***

It is necessary to refer once more to the danger of life from high voltage current if the shutdown procedures are not observed. High voltage equipment must not be opened - the plug must first be taken out - otherwise there is danger of electric shock.

### ***Powder***

Powder/air mixtures can be ignited by sparks. There must be sufficient ventilation in the powder coating booth. Powder lying on the floor around the powder spraying device is a potentially dangerous source of slipping.

### ***Static charges***

Static charges can have the following consequences: Charges to people, electric shocks, sparking. Charging of objects must be avoided - see "Earthing".

### ***Grounding***

All electricity conducting parts and machinery found in the workplace (according to DIN VDE 0745, part 102) 1,5 meters either side and 2,5 meters around each booth opening, have to be grounded. The earthing resistance must amount to maximally 1 MOhm. The resistance must be tested regularly. The condition of the work piece attachments as well as the hangers must guarantee that the work pieces remain grounded. If the grounding of the work pieces takes place by their attachments, these must constantly be kept clean in order to guarantee the necessary conductivity. The appropriate measuring devices must be kept ready in the workplace in order to check the earthing.

### ***Compressed air***

When there are longer pauses or standstill times between working, the powder spraying equipment should be drained of compressed air. There is a danger of injury when pneumatic hoses are damaged and from the uncontrolled release and improper use of compressed air.

### ***Crushing and cutting***

During operation, moving parts may automatically start to move in the operating area. It must be ensured that only instructed and trained personnel go near these parts. The operator should ensure that barriers comply with the local security regulations.

### ***Access under exceptional circumstances***

The user enterprise has to ensure due to the local conditions, that when repairs at the electrical part or restarting operation activities are done, additional measures such as providing with gates against the admission of unauthorized persons are absolutely executed.

### ***Prohibition of unauthorized conversions and modifications to machines***

All unauthorized conversions and modifications to electrostatic spraying equipment are forbidden for safety reasons.

The powder spraying equipment should not be used if damaged, and the faulty part must be immediately replaced or repaired. Only original ITW Gema spare parts may be used! Damage caused by other parts is not covered by guarantee.

Repairs must only be carried out by specialists or in ITW-Gema workshops. Arbitrary, unauthorized repairs can lead to injuries and damages to the equipment! The ITW Gema AG guarantee would no longer be valid.

## Safety requirements for electrostatic powder coating

1. This equipment can be dangerous, if the instructions in this operating manual are not followed.
2. All electrostatic conductive parts, in particular the machinery within 5 meters of the coating equipment, must be earthed.
3. The floor of the coating area must conduct electricity (normal concrete is generally conductive).
4. The operating personnel must wear electrically conductive footwear (e.g. leather soles).
5. The operating personnel should hold the gun with bare hands. If gloves are worn, these must also conduct electricity.
6. The supplied grounding cable (green/yellow) must be connected to the grounding screw of the manual electrostatic powder spraying equipment. The grounding cable must have a good metal to metal connection with the coating booth, the recovery unit and the work piece conveyor system, especially with the work piece suspension.
7. The electricity and powder supply to the hand guns must be set up in such a way that they are fully protected against heat and chemical damage.
8. The powder coating equipment may be able to be switched on only if the booth is in operation. If the booth cuts out then the powder coating device must be switched off.
9. The earthing of all electricity conducting devices (e.g. hooks, conveyor chains) must be checked on a weekly basis. The earthing resistance must amount to maximally 1 MOhm.
10. The control unit must be switched off, if the hand gun is cleaned or the nozzle is changed.
11. When working with cleaning agents there may be a risk of hazardous fumes. The manufacturers instructions must be observed when using such cleaning agents.
12. The manufacturers instructions and the applicable environmental requirements must be observed when disposing of powder lacquer and cleaning agents.
13. If any part of the spray gun is damaged (broken parts, tears) or missing then it should not be used.
14. For your own safety, only use accessories and attachments listed in the operating instructions. The use of other parts can lead to risk of injury. Only original ITW-Gema replacement parts should be used.
15. Repairs must only be carried out by specialists and under no circumstances should they be carried out in the operating area. The former protection must not be reduced.
16. Conditions leading to dangerous levels of dust concentration in the powder spraying booths or in the powder spraying areas must be avoided. There must be sufficient technical ventilation available, to prevent a dust concentration of more than 50% of the lower explosion limit (UEG) (UEG = max. permissible powder/air concentration). If the UEG is not known then a value of 10 g/m<sup>3</sup> should be used.

## A summary of the rules and regulations

The following is a list of relevant rules and regulations which are to be observed:

### **Guidelines and regulations, German professional association**

BGV A1	General regulations
BGV A2	Electrical equipment and material
BGI 764	Electrostatic coating
BGR 132	Guidelines for the avoidance of the dangers of ignition due to electrostatic charging (Guideline "Static Electricity")
VDMA 24371	Guidelines for electrostatic coating with synthetic powder <sup>1)</sup> - Part 1 General requirements - Part 2 Examples of use

### **Leaflets**

ZH 1/310	Leaflet for the use of tools in locations where there is danger of explosion <sup>1)</sup>
----------	--

### **EN European standards**

RL94/9/EC	The approximation of the laws of the Member States relating to apparatus and safety systems for their intended use in potentially explosive atmospheres
EN 292-1 EN 292-2	Machine safety <sup>2)</sup>
EN 50 014 to EN 50 020, identical: DIN VDE 0170/0171	Electrical equipment for locations where there is danger of explosion <sup>3)</sup>
EN 50 050	Electrical apparatus for potentially explosive atmospheres - Electrostatic hand-held spraying equipment <sup>2)</sup>
EN 50 053, part 2	Requirements for the selection, installation and use of electrostatic spraying equipment for flammable materials - Hand-held electrostatic powder spray guns <sup>2)</sup>
EN 50 177	Stationary electrostatic spraying equipment for flammable coating powder <sup>2)</sup>
EN 12981	Coating plants - Spray booths for application of organic powder coating material - Safety requirements
EN 60 529, identical: DIN 40050	IP-Type protection; contact, foreign bodies and water protection for electrical equipment <sup>2)</sup>
EN 60 204 identical: DIN VDE 0113	VDE regulations for setting-up high voltage electrical machine tools and processing machines with mains voltages up to 1000 V <sup>3)</sup>

### **VDE (Association of German Engineers) Regulations**

DIN VDE 0100	Regulations for setting-up high voltage equipment with mains voltages up to 1000 V <sup>4)</sup>
DIN VDE 0105, part 1 part 4	VDE regulations for the operation of high voltage equipment <sup>4)</sup> General regulations Supplementary definitions for stationary electrical spraying equipment
DIN VDE 0147 part 1	Setting up stationary electrostatic spraying equipment <sup>4)</sup>
DIN VDE 0165	Setting up electrical equipment in locations in areas with danger of explosion <sup>4)</sup>

**\*Sources:**

- 1) Carl Heymanns Verlag KG, Luxemburger Strasse 449, 5000 Köln 41, or from the appropriate employers association
- 2) Beuth Verlag GmbH, Burggrafenstrasse 4, 1000 Berlin 30
- 3) General secretariat, Rue Bréderode 2, B-1000 Bruxelles, or the appropriate national committee
- 4) VDE Verlag GmbH, Bismarckstrasse 33, 1000 Berlin 12

---

## **Product specific security measures**

- The installation work, to be done by the customer, must be carried out according to local regulations
- Before starting up the plant a check must be made that no foreign objects are in the booth or in the ducting (input and exhaust air)
- It must be observed, that all components are grounded according to the local regulations, before start-up

# About this manual

---

## General information

This operating manual contains all the important information which you require for the working with the OptiFlex BN Powder coating equipment. It will safely guide you through the start-up process and give you references and tips for the optimal use of your new powder coating system.

Information about the function mode of the individual system components - booth, gun control unit, manual gun or powder injector - should be referenced to their enclosed corresponding documents.



# Function description

---

## Field of application

The OptiFlex BN powder coating equipment (with stirrer) is built exclusively for electrostatic coating with organic powders. Any other use is considered as non-conform. The manufacturer is not responsible for any damage resulting from this - the risk for this is assumed by the user alone!

The OptiFlex BN Electrostatic Powder Manual equipment for Boron Nitride with the OptiSelect Manual powder gun or OptiGun-A Automatic powder gun are ideally suited for spraying short bursts of fine grained powder with small powder output volumes.

---

## Typical characteristics

- Processing the powder from the stirrer recipient
- Quick and simple color change
- Supplied ready for use
- Available with one or two guns (extensible)

# OptiFlex BN Powder coating equipment

## Structure



*OptiFlex BN Powder coating equipment - structure*

- |   |                              |    |                                  |
|---|------------------------------|----|----------------------------------|
| 1 | OptiStar control unit        | 8  | Hose holder                      |
| 2 | OptiSelect manual powder gun | 9  | Hose connections                 |
| 3 | OptiFlow injector            | 10 | Discharge flap                   |
| 4 | Mobile frame with hand rail  | 11 | Filler flap                      |
| 5 | Stirrer recipient            | 12 | Shelf                            |
| 6 | Swivel wheel                 | 13 | Rubber wheel                     |
| 7 | Filter unit                  | 14 | OptiGun 2-A automatic powder gun |

## OptiStar control unit

All information about the OptiStar control unit will be found in the corresponding enclosed documentation!

## OptiFlow injector

All information about the OptiFlow injector will be found in the corresponding enclosed documentation!

## Powder guns and powder hoses

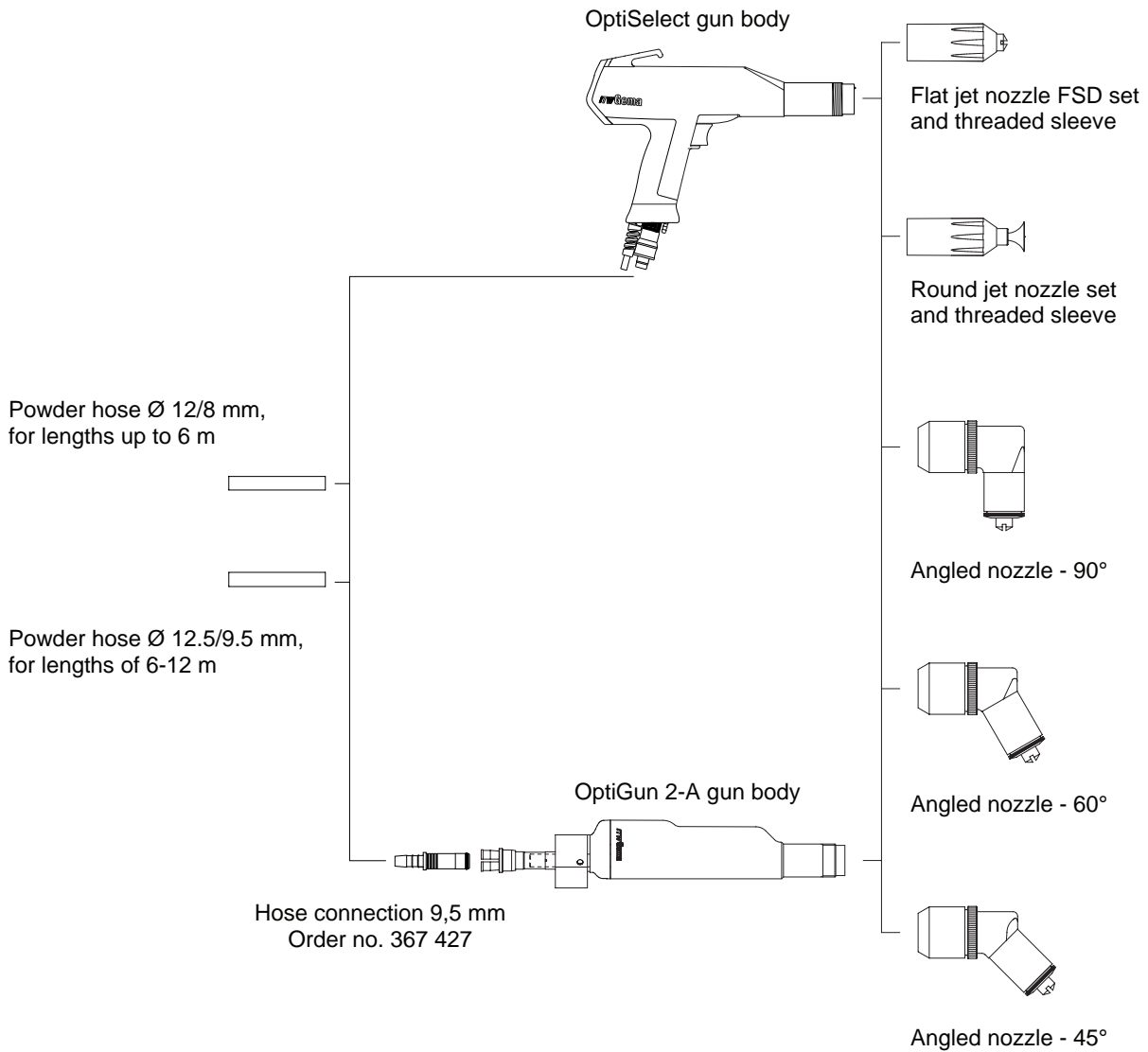

*Powder guns and powder hoses - overview*

## Stirrer hopper

The powder in the stirrer hopper is agitated and kept loose by the stirrer arm. The injector sucks in the powder by means of the conveying air (1). The powder/air mixture attains to the gun through the powder hose (2) and is electrostatically charged in the gun nozzle. In addition, an electrostatic field is created between the gun nozzle and the grounded object. The electrostatically charged powder sprayed onto the workpiece adheres on the surface of the grounded object. Because of the conical shape of the stirrer recipient, the powder can be used completely (optimum powder consumption).

Conveying air, supplementary air and rinsing air are set on the OptiStar control unit (see therefore the corresponding user manual). The function of the used injector is described in the corresponding user manual.

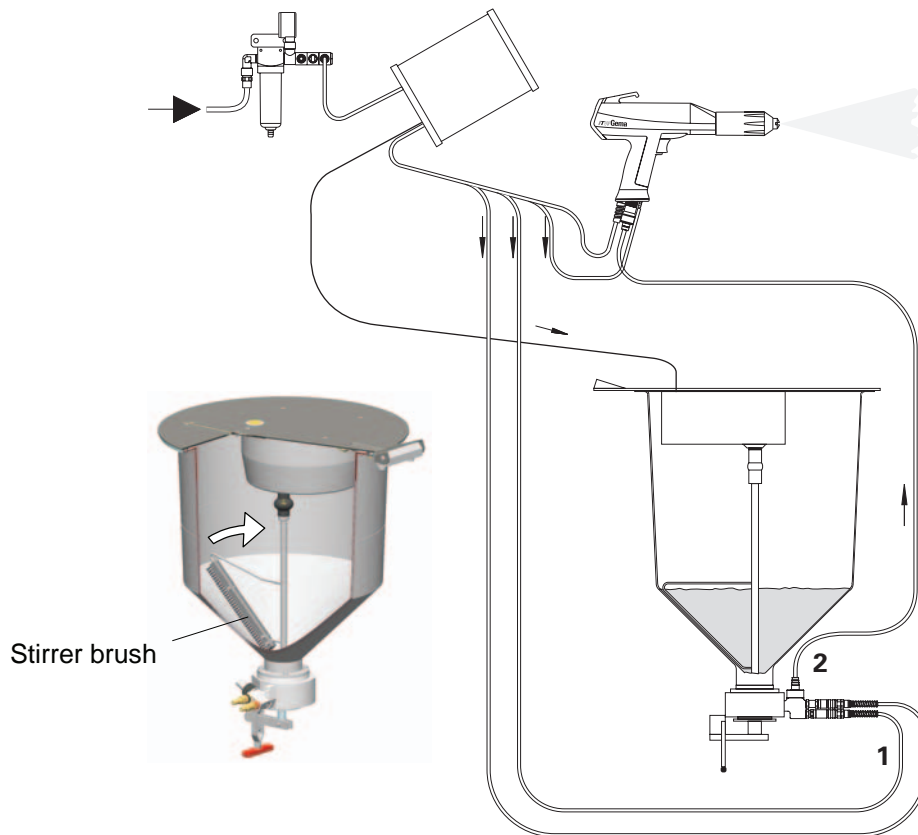

Stirrer hopper - function

---

## Scope of delivery

### OptiFlex 1-BN

- A OptiStar control unit in a metal case with power supply cable
- A mobile trolley with a gun/hose support
- A powder hopper with stirrer and cover, inclusive mains adaptor for the stirrer
- A plug-in OptiFlow injector
- An OptiSelect manual powder gun or an OptiGun-A Automatic powder gun with gun cable, powder hose, rinsing air hose and standard nozzle set (see therefore the OptiSelect manual powder gun/OptiGun-A Automatic powder gun user manual)
- Adapter: only for use with an OptiGun-A Automatic powder gun (See OptiGun-A Automatic powder gun operating instructions)
- Pneumatic hoses for conveying air (red) and fluidizing air (black)

### Additional supply for OptiFlex 2-BN

- An additional OptiStar control unit, complete with gun holder, special powder supply cable and connecting material
- An additional OptiSelect manual powder gun or an OptiGun-A Automatic powder gun with gun cable, powder hose, rinsing air hose and standard nozzle set
- Pneumatic hoses for conveying air (red), supplementary air (black), as well as a pneumatic connection with dual distributor from pressure reducing valve to control unit
- Mains adaptor for twin equipment



# Technical data

---

## OptiFlex BN Powder coating equipment

### Electrical data

OptiFlex BN	
Nominal input voltage	230-240 VAC (110-120 VAC)
Operating frequency	50/60 Hz
Input power	150 VA
Nominal output voltage (to the gun)	max. 12 V
Nominal output current (to the gun)	max. 1 A
Protection type	IP54
Temperature range	0 - 40°C
Approval	

### Pneumatic data

OptiFlex BN	
Compressed air main connection	G1/4" - female thread
Max. input pressure	10 bar
Min. input pressure	6 bar
Max. water vapor content of the compressed air	1,3 g/m <sup>3</sup>
Max. oil vapor content of the compressed air	0,1 mg/m <sup>3</sup>
Max. compressed air consumption	7 m <sup>3</sup> /h

### Connectable guns

OptiFlex BN	connectable
OptiSelect GM02	yes
OptiGun GA02	yes
PG1/PG2-A	yes (no remote control)
TriboJet	yes, with adaptor*

\* The gun type must be set on the control unit (see therefore the corresponding user manual)!



**Attention:**

**The OptiFlex BN powder coating equipment can only be used with the specified gun types!**

### Dimensions

OptiFlex BN	
Width	691 mm
Depth	764 mm
Height	1135 mm
Weight	58 kg

# Start-up and operation

---

## Connecting guide



1. Check the compressed air connection from the filter unit to the control unit. Connect the compressed air supply hose from the compressed air circuit directly to the filter unit main connection on the rear side of the equipment (1/4" female BSP)

---

**Note:**

**The compressed air must be free from oil and water!**

---

2. Connect the grounding cable to the control unit with the grounding screw, and the 5 m long grounding cable with the clamping clip to the booth or the conveyor. Check ground connections with Ohm meter and ensure 1 MOhm or less
3. Connect the gun cable plug to the socket **2.3** on the rear side of the control unit
4. Connect the rinsing air hose to the electrode rinsing air output **1.4** and to the powder gun
5. Attach the injector, connect the powder hose to the injector and to the powder gun



---

**Note:**

**Depending on the layout of the powder hoses, the following hoses are to be used:**

**By lengths up to 6 m = hose Ø 12/8 mm**

**By lengths of 6-12 m = hose Ø 12.5/9.5 mm**

---

6. Connect the red hose for the conveying air to the corresponding output **1.2** on the rear of the control unit and to the injector
7. Connect the black hose for supplementary air to the corresponding output **1.3** on the rear side of the control unit and to the injector (this hose is electrically conductive)
8. Connect the mains cable to the **2.1 Power IN** plug and screw it on



---

**Note:**

**If no stirrer motor is connected, close the 2.2 Aux output with the provided dust protection cap!**

---

## Adapter for external triggered powder guns (Boron Nitride adapter)

A OptiSelect Manual powder gun (GM02) or a OptiGun Automatic powder gun (GA02) can be connected to an OptiStar Gun control unit and externally triggered by short-circuiting the two cables of the adaptor piece.

The adaptor must be switched between the powder gun and the OptiStar control unit.

The two wire cable can be connected to a relay output of a PLC, which short-circuits both.

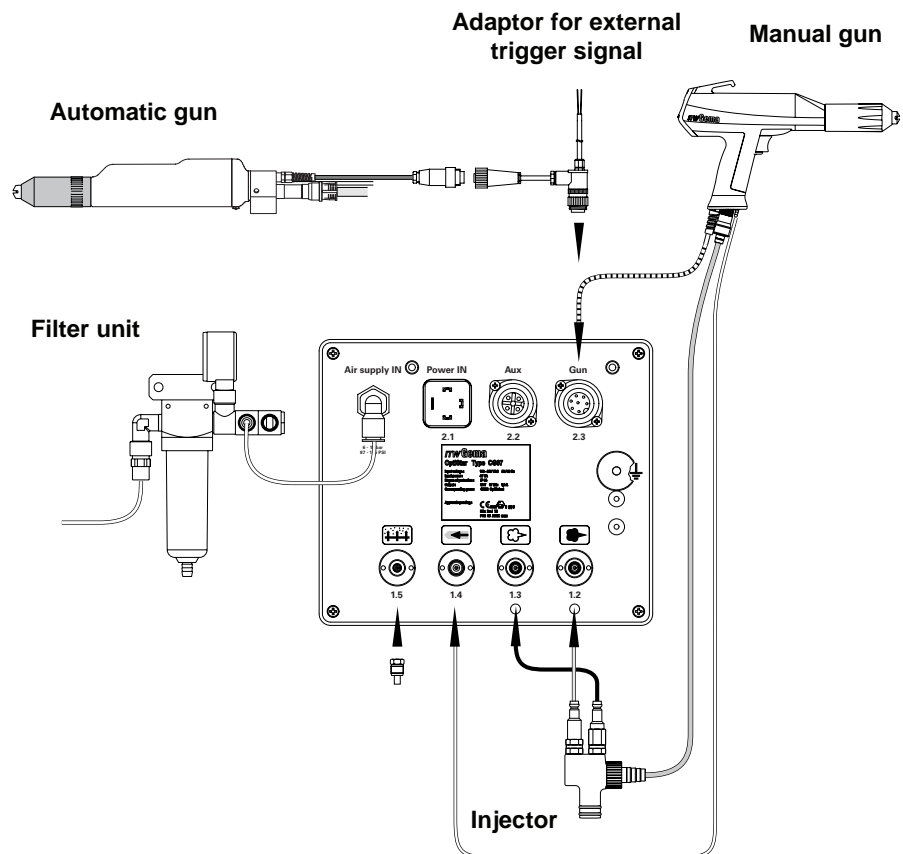

Connecting guide - overview

---

## Preparation for start-up

### Fill the stirrer recipient with powder

1. Open the hinged flap of the stirrer recipient cover
2. Fill in the coating powder in the stirrer recipient. Maximum filling level of the powder is marked on the inside of the recipient (useful capacity approx. 18.5 dm<sup>3</sup>)
3. Close the hinged flap of the stirrer recipient cover
4. The stirrer can be put into operation by pressing manually the button on the cover when filling/emptying

### Switch on the booth

The coating booth is switched on according to the corresponding user manual.

---

## Start-up

### Stirrer

The stirrer starts by pressing the gun trigger. By letting loose the gun trigger, the stirrer runs after for approx. 15-20 seconds. So open the cover only after the stirrer has stopped! By raising the stirrer cover, the engine switches off.

### Switch on the control unit

1. Press the **ON** power switch.  
The displays illuminate and the control unit is ready for operation



---

**Note:**

**The further start-up procedure for the OptiFlex BN Powder coating equipment is explicitly described in the OptiStar CG07 control unit operating instructions (chapter "Initial start-up" and "Daily start-up")!**

---



# Color change

---

## General information

When a color change takes place, the individual components of the manual coating equipment must be cleaned carefully. Thereby, all powder particles of the former color must be removed!

**Procedure:**

1. Empty the stirrer recipient and clean thoroughly
2. Clean the powder hose:
  - Strip the powder hose from the hose connection on the injector
  - Point the gun into the booth
  - Blow through the hose manually with a compressed air gun
  - Fit the powder hose again to the hose connection on the injector
3. Dismantle and clean the powder gun (see therefore OptiSelect Manual powder gun user manual)
4. Clean the injector (see therefore the OptiFlow Injector user manual)
5. Prepare the manual coating equipment with new powder for start-up



# Maintenance and cleaning



---

**Note:**

**Regular and conscientious maintenance increases the life span of the manual coating equipment and provides for a longer continuous coating quality!**

---

---

## Daily maintenance

1. Clean the injector (see therefore the user manual of the OptiFlow injector)
2. Clean the powder gun (see therefore the user manual of the OptiSelect manual powder gun)
3. Clean the powder hose, see therefore in chapter "Color change"

---

## Weekly maintenance

1. Clean the powder hopper, injector and powder gun.
2. Check the control unit grounding connections to the coating booth, the suspension devices of the work pieces, or the conveyor chain

---

## If in disuse for several days

1. Remove the mains plug
2. Clean the coating equipment
3. Turn off the compressed air main supply

### Powder hose rinsing

If lengthy downtimes take place, the powder hose must be cleaned.

**Procedure:**

1. Strip the powder hose from the hose connection on the injector
2. Point the gun into the booth
3. Blow through the hose manually with a compressed air gun
4. Fit the powder hose again to the hose connection on the injector

## Cleaning

### Cleaning the OptiSelect manual powder gun

Frequent cleaning of the gun helps to guarantee the coating quality.



**Note:**

**Before cleaning the powder gun, switch off its control unit. The compressed air used for cleaning must be free from oil and water!**

**Daily:**

1. Blow off the outside of the gun and wipe, clean etc.

**Weekly:**

2. Remove the powder hose from the connection
3. Remove the spray nozzle from the gun and clean it
4. Blow out the gun from the connection in flow direction with compressed air
5. Clean the integrated gun tube with the provided gun brush
6. Blow through the gun with compressed air again
7. Clean the powder hose
8. Reassemble the gun and connect it



**Note:**

**See therefore the user manual of the OptiSelect manual powder gun!**

## Maintenance and cleaning of the filter unit

The filter unit on the OptiFlex BN powder coating equipment measures and cleans the compressed air. Here, the main compressed air connection of the equipment is located.

### Replacing the filter element

**Procedure:**

1. Unscrew the filter glass on the filter unit
2. Loose the cap screw
3. Remove the complete filter element
4. Replace the filter element
5. Clean the filter glass on the inside and install it again

# Troubleshooting

## General information

Fault	Causes	Troubleshooting
---	Power pack defective	Replace the power pack, if error is permanent
---	Main valve defective	Replace main valve coil
---	Gun not connected Gun plug, gun cable or gun cable connection defective Remote control on powder gun defective	Connect the gun Replace corresponding part or send in for repair Replace remote control (gun back cover)
---	Rinsing air solenoid valve of flat jet nozzle defective	Replace valve coil
---	Rinsing air solenoid valve of round jet nozzle defective	Replace valve coil
---	Gun plug, gun cable or gun cable connection defective	Replace corresponding part or send in for repair
Gun LED remains dark, although the gun is triggered	Gun plug, gun cable or gun cable connection defective Remote control on powder gun defective	Replace corresponding part or send in for repair Replace remote control (gun back cover)
Powder does not adhere to object, although the gun is triggered and sprays powder	High voltage and current deactivated High voltage cascade defective Objects are not properly grounded	Press the selection key (application key) Send in the gun for repair Check the grounding

Fault	Causes	Troubleshooting
Control unit displays remain dark, although the control unit is switched on	Control unit is not connected to the mains Power pack fuse defective Power pack defective	Connect the equipment with the mains cable Replace the fuse  Replace the power pack, if error is permanent
The powder is not fluidized	Compressed air not present Fluidizing air is set too low on the control unit Throttle motor defective	Connect the equipment to the compressed air Set the fluidizing air correctly Replace throttle motor
The gun does not spray powder, although the control unit is switched on and the gun is triggered	Compressed air not present Injector, throttle motor or nozzle on injector, powder hose or powder gun are clogged Insert sleeve in the injector is clogged Insert sleeve is not installed Fluidizing not running No conveying air: Throttle motor defective Solenoid valve defective Front plate defective	Connect the equipment to the compressed air Clean corresponding part  Replace Install the insert sleeve  (see above) Replace the throttle motor Replace the solenoid valve Send for repair

# Schematic diagrams

## OptiFlex BN - block diagram

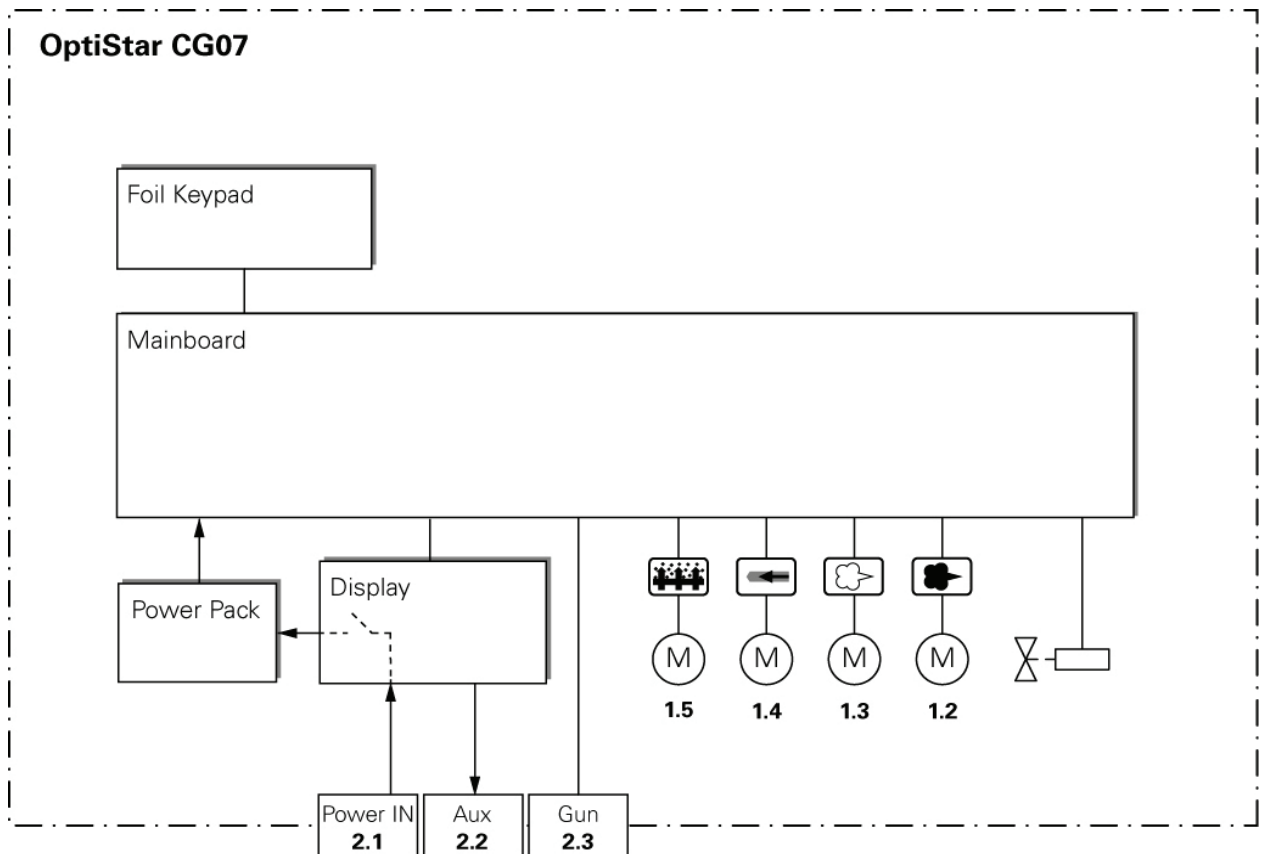

OptiFlex BN - block diagram

# OptiFlex BN Powder coating equipment - pneumatic diagram

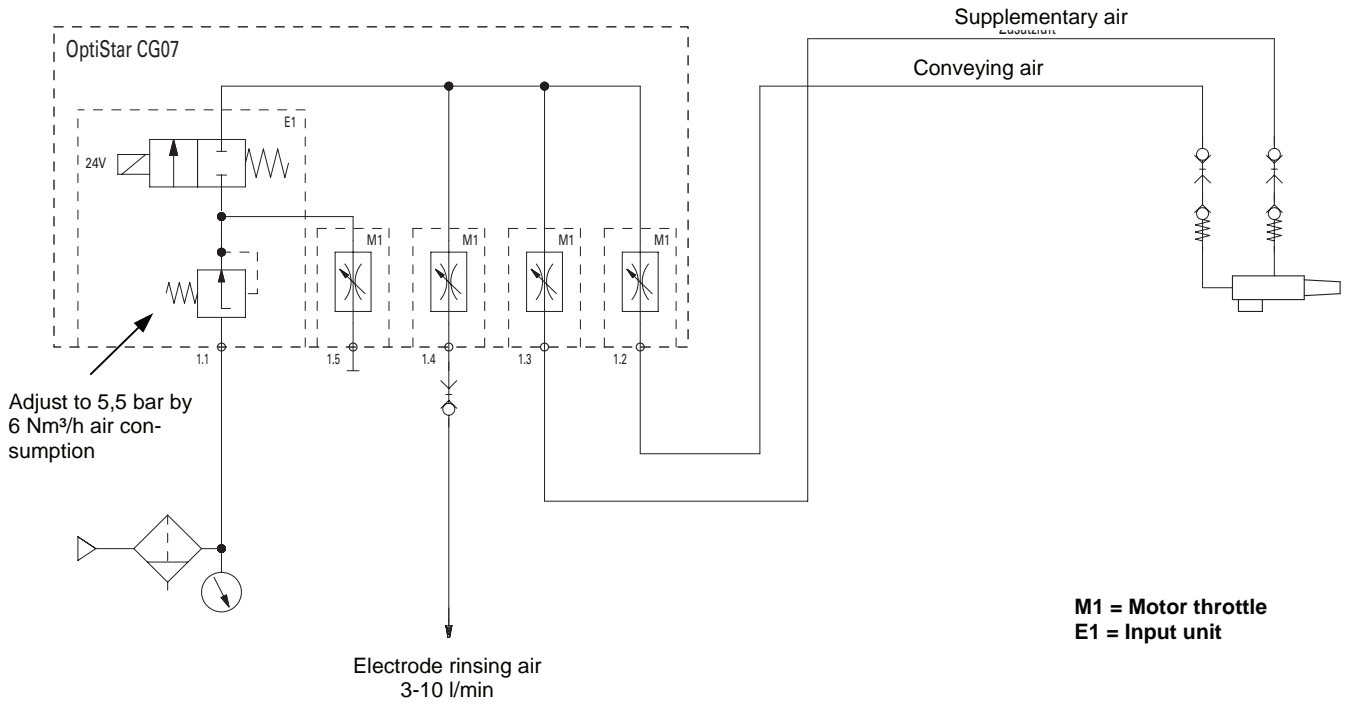

OptiFlex BN Powder coating equipment - pneumatic diagram

# Spare parts list

---

## Ordering spare parts

When ordering spare parts for powder coating equipment, please indicate the following specifications:

- Type and serial number of your powder coating equipment
- Order number, quantity and description of each spare part

**Example:**

- **Type** OptiFlex BN Powder coating equipment  
**Serial number** 1234 5678
- **Order no.** 203 386, 1 piece, Clamp - Ø 18/15 mm

When ordering cable or hose material, the required length must also be given. The spare part numbers of this yard/meter ware is always marked with an \*.

The wear parts are always marked with a #.

All dimensions of plastic hoses are specified with the external and internal diameter:

**Example:**

Ø 8/6 mm, 8 mm outside diameter (o/d) / 6 mm inside diameter (i/d)



---

**WARNING!**

**Only original ITW-Gema spare parts should be used, because the explosion protection will also be preserved that way. The use of spare parts from other manufacturers will invalidate the ITW Gema guarantee conditions!**

---

---

## OptiFlex BN - spare parts list

1	Bearing bolt	1000 453
2	Handle piece, right	1000 811
3	Handle piece, left	1000 812
4	Handle bar	1000 460
5	Counter washer	1000 454
6	Rubber wheel - Ø 200 mm	260 592
7	Swivel wheel - Ø 50 mm	260 606
9	Bearing bolt - L=48 mm	1000 952
10	Conical spring washer	1000 943
11	Compression spring - 0,63x8x16 mm, RF	1000 565
12	Gun retainer	1001 140
13	CG07 Gun control unit - complete (see corresponding operating manual)	
14	Bumper	1000 779
15	Hose holder	1000 699
16	Filter unit - complete (see corresponding spare parts list)	
17	Stirrer hopper (see corresponding spare parts list)	
18	Shakeproof Allen screw - M10x20 mm	260 584
19	Snap ring - A	237 094
20	Shakeproof Allen screw - M8x12 mm	261 793
21	OptiFlow IG02-V injector - complete (see corresponding user manual)	
22	Adapter for external trigger signal	1002 772

# Wearing part

\* Please indicate length

# OptiFlex BN - spare parts list

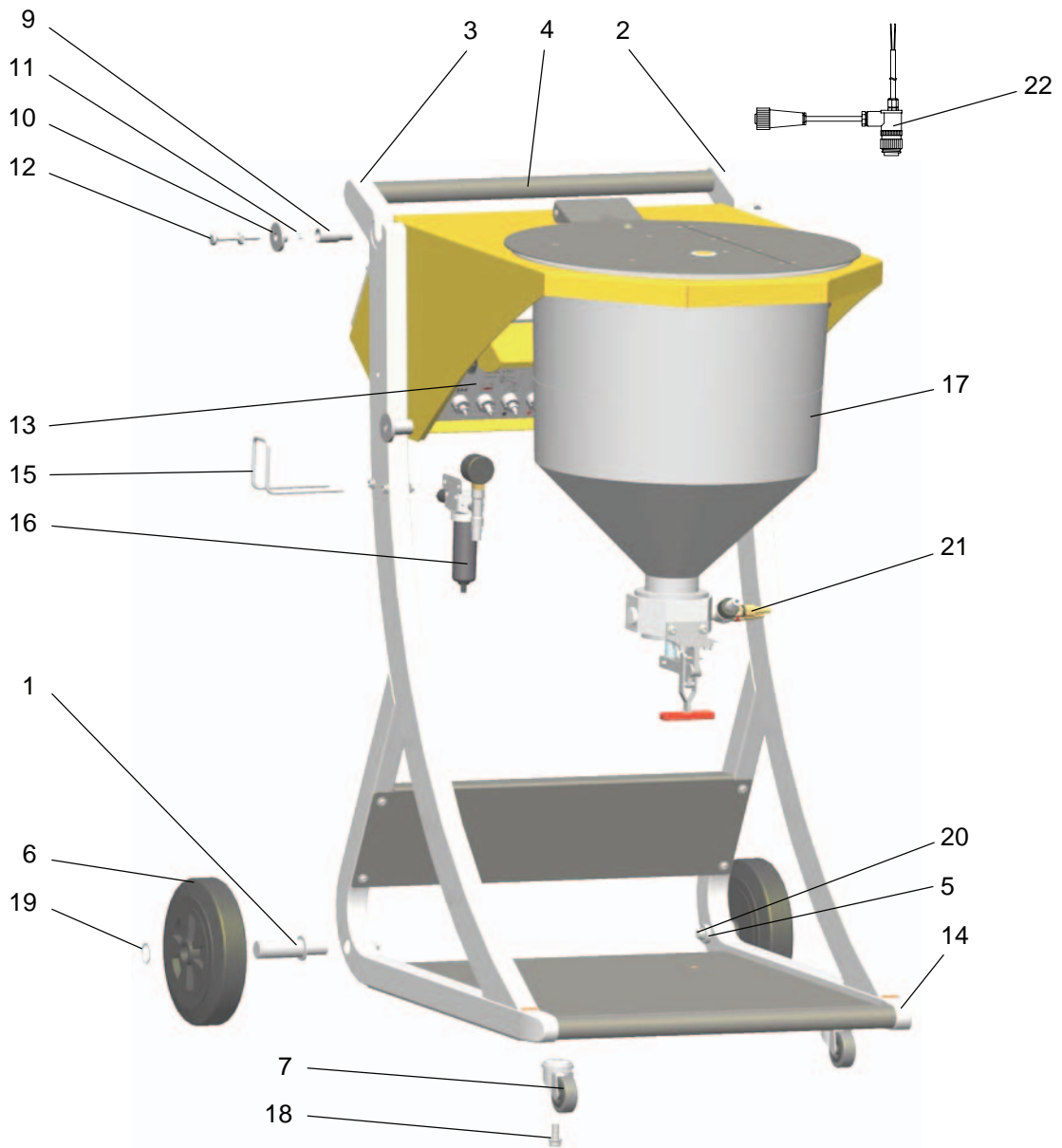

*OptiFlex BN Powder coating equipment - spare parts*

---

## OptiFlex BN - stirrer hopper

1	Mini stirrer brush	366 862
2	Main filler cover	1001 730
3	Filler flap	1001 731
4	Hinge	305 472
5	Powder container	366 854
6	Gasket for powder container	101 630*
7	Cardan joint - Ø 12 mm, H8	206 369
	Feather key for cardan joint - 4x4x16 mm, round	206 075
	Allen grub screw for cardan joint - sharp, M4x5 mm	214 728
8	Protective sleeve for cardan joint	206 350
9	Manifold	379 395
10	O-Ring - Ø 67,2 mm	236 403#
11	Gasket for discharge flap	303 240
12	Discharge flap with toggle clamp	303 194
13	Blind grommet incl. item 14	380 296
14	O-ring for blind grommet	231 517
15	Injector holder	380 288
16	Stirrer brush	377 660#
17	Cap screw - M4x12 mm	216 798
18	Guide ring	380 318#

# Wearing part

\* Please indicate length

# OptiFlex BN - stirrer hopper

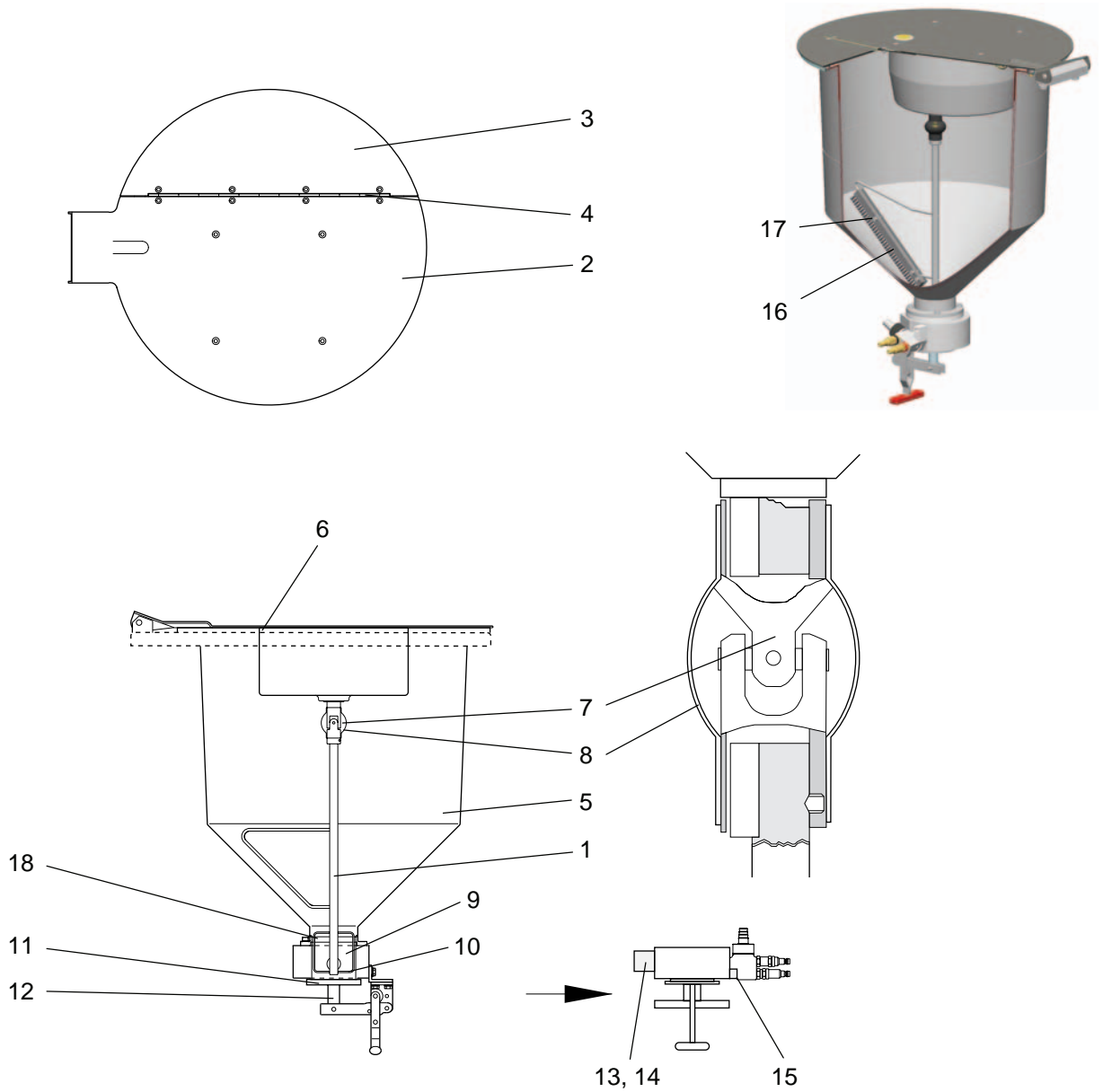

OptiFlex BN - Stirrer hopper

---

## OptiFlex BN - stirrer drive unit

	Stirrer drive unit - complete (pos. 1-13)	393 940
1	Stirrer motor (with gear and stirrer case)	393 932
2	Stirrer motor (with pinion)	268 950
	Stirrer motor	269 255
	Drive belt	268 941#
3	Electronic board for stirrer control	388 173
4	Stirrer control power supply	389 277
5	Mains push button - complete, with cable	390 542
	Cable set, consisting of:	
6	Power pack connecting cable	390 550
7	Connecting cable - 24 VDC	390 569
8	Grounding wire	391 867
9	Fixture set for power pack board, consisting of two pieces each:	
	Standoff - M3, SW5,5x12 mm	267 775
	Standoff - M3, SW5,5x10 mm	267 007
	Cylinder screw	245 321
	Shake proof washer	205 885
10	Fuse - 2 AT	221 872
11	Adaptor cable for stirrer connection	391 905
12	Gland	265 780
13	Gasket for stirrer motor	393 924

# Wearing part

\* Please indicate length

# OptiFlex BN - stirrer drive unit

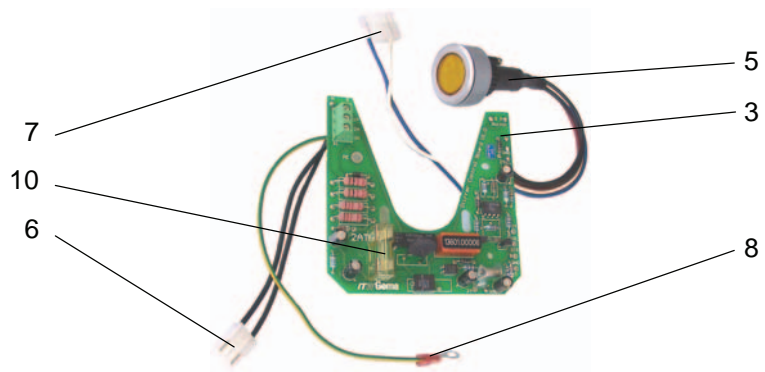
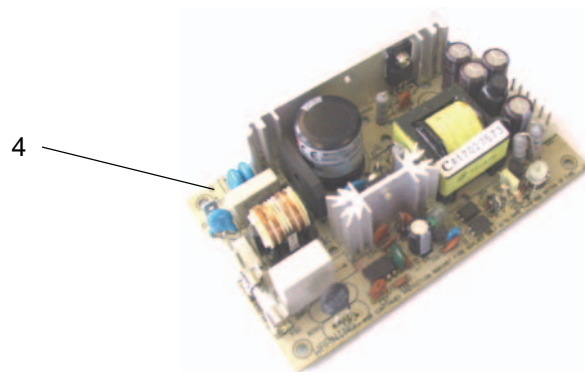
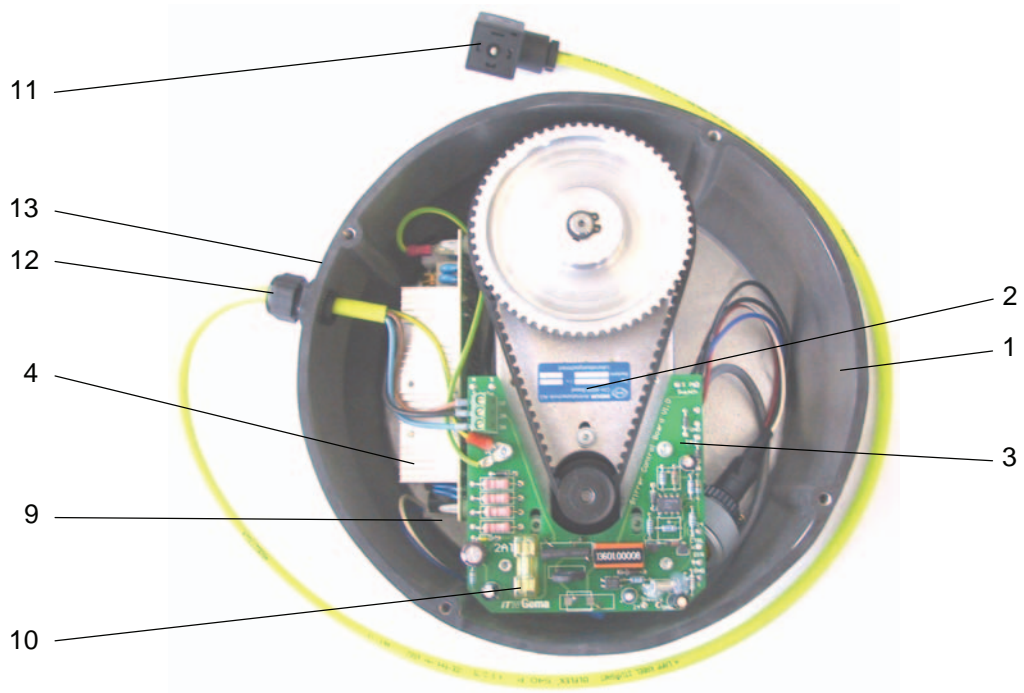

*OptiFlex BN - stirrer drive unit*

## OptiFlex BN - filter unit

	Filter unit - complete, without pos. 13	1001 147
1	Filter separator body - F14MD	1001 759
2	T-piece - 1/4"i-1/4"a-1/4"i	262 064
3	Elbow joint - 1/4"-Ø 8/3x1 mm	1002 614
5	Fixture plate complete	1001 758
6	Condensate container with drain valve	1001 761
7	Filter cartridge - 20 µm	1001 762
8	Cap screw - M4x60 mm	258 946
9	Pressure gauge - 1/4"a, 0-10 bar	1001 764
10	Rectus connector - NW 7,4-1/4"a	256 730
11	Plug - Ø 8 mm	238 023
12	Elbow connection - 1/4"a-1/4"i	222 674
13	Rectus Quick-release coupling (for pos. 10, not shown)	239 267

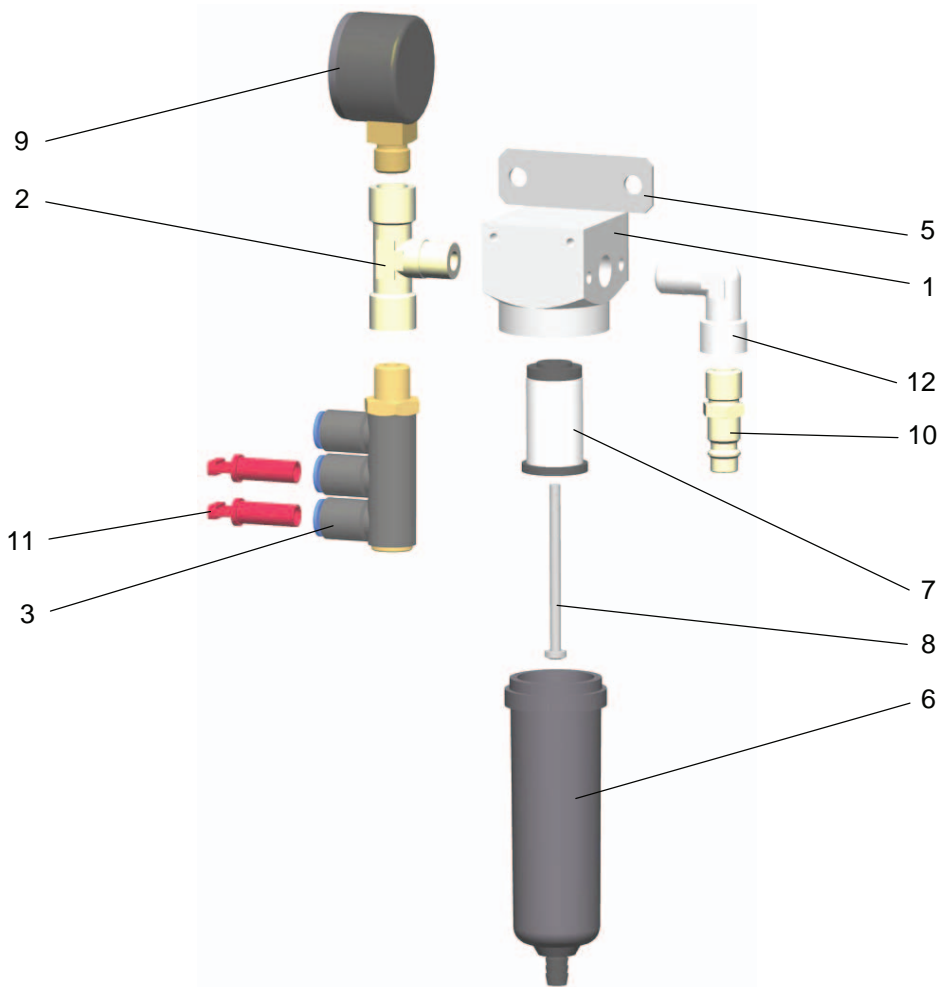

OptiFlex BN - Filter unit

