

Operating Instructions and Spare Parts List

OptiGun 2-AE Automatic Powder Gun (GA02)



Table of Contents

1. Operating Instructions	1
1.1. Safety rules for electrostatic powder coating operations	1
2. About these operating instructions	1
3. Field of application	1
4. OptiGun 2-AE Automatic Powder Gun	2
4.1. Scope of delivery	2
4.2. Technical data - OptiGun 2-AE Automatic Powder Gun	3
5. OptiGun 2-AE Automatic Powder Gun - Overview	4
5.1. Spray Nozzles	5
5.2. High-voltage generation	6
5.3. Circuitry	6
5.4. Powder flow and rinsing air	7
5.5. Flat jet nozzle with vented central electrode	8
5.6. Round jet nozzle with deflector and vented central electrode	8
6. Preparation of the Start-up	9
6.1. Connect the OptiGun 2-AE Automatic Powder Gun	9
6.2. Function check	10
7. Start-up	11
7.1. Regulating the powder output and powder cloud	11
7.2. Setting the Total air volume	11
7.3. Selecting the powder output volume	11
7.4. Selecting Electrode rinsing	11
7.5. Setting-up – Powder coating	12
7.6. Shut-down	12
7.7. Powder hose rinsing	12
8. Maintenance plan	13
8.1. Daily maintenance	13
8.2. Weekly maintenance	13
9. Cleaning and repairs	13
9.1. Cleaning	13
9.1.1. Daily	13
9.1.2. Weekly	13
9.2. Dismantling the powder gun	14
9.3. Powder gun re-assembly	19
9.4. Repairs to the powder gun	20
9.5. Cleaning the spray nozzles	20
10. Troubleshooting Guide	21

(Cont.)

Table of Contents (cont.)

11. Spare Parts List	23
11.1. Ordering spare parts	23
11.2. OptiGun 2-AE Automatic Powder Gun	24
11.3. OptiGun 2-AE Automatic Powder Gun - complete	24
11.4. Powder gun body OptiGun 2-AE - complete	25
11.5. Shaft OptiGun 2-AE - complete	25
11.6. Powder gun cable - complete	26
11.7. Nozzle combinations for OptiGun 2-AE	27
11.8. Nozzle combinations for OptiGun 2-AE - Angled Nozzle	28
11.9. OptiGun 2-AE - SuperCorona	29

1. Operating Instructions

1.1. Safety rules for electrostatic powder coating operations

1. This equipment is dangerous when not operated according to the following standards: EN 50 050 (or VDE 0745, Part 100), EN 50 053, Part 2 (or VDE 0745, Part 102) and the Specification Sheet ZH 1/444 for electrostatic powder coating.
2. All electrically conductive parts located within 5 m of the coating area and especially the workpieces must be properly grounded.
3. The floor in the coating area must be electrically conductive. Normal concrete is generally conductive.
4. The operating personnel must wear electrically conductive footwear (e.g. leather soles).
5. The operating personnel should hold the gun in the bare hand. If gloves are worn, they must be electrically conductive.
6. Connect the grounding cable (yellow/green) supplied to the grounding terminal on the control module. The grounding cable must have a good metal to metal connection with the coating booth, recovery unit, and the workpiece conveyor system, especially with the workpiece suspension.
7. The electrical, and powder feed lines to the guns must be laid out so that they are protected from possible mechanical damage.
8. The powder coating equipment should only be switched on after the booth is in operation. If the booth breaks down then the powder coating equipment must also switch off.
9. Check the grounding of all electrically conductive parts at least once a week.
10. When cleaning the gun or changing nozzles the control module must be switched off.

2. About these operating instructions

These operating instructions contain all important information which is required to operate your OptiGun 2-AE powder gun. It will guide you safely through the installation stage, give you information to expand the use of your powder gun through the various accessories, it will give you notes and tips for the optimum use of your new powder gun. Information about the functioning of individual system components, powder gun controls, injectors etc., will be found in the respective documentation.

3. Field of application

The OptiGun 2-AE Automatic Powder Gun is built exclusively for the electrostatic coating with anorganic (enamel) powders. Any other use beyond this is not intended. The manufacturer is not responsible for any damage resulting from this; the risk for this is carried by the user alone.

4. OptiGun 2-AE Automatic Powder Gun

The extremely light OptiGun 2-AE Automatic Powder Gun with integrated high voltage generation convinces through optimum penetration power and high charging. A high, constant transfer efficiency and a high coating efficiency with symmetrical coating structure are achieved with the vented central electrode. The OptiGun 2-AE automatic powder gun can be easily dismantled and is therefore maintenance and repair-friendly.

- Continuous, tightly sealed gun bodies with separate channels for cascade and rinsing air
- Continuous guided powder tube, self-sealing
- Quickly dismantled SuperCorona ring
- Powder tube coupling with quick-release mechanism
- Covered hose and cable
- Excellent access to the connections due to the snap lock
- Easily dismantled with a few hand movements, therefore, easy to service
- few wear parts (powder tube, nozzle, and SuperCorona)
- self-sealing powder tube (housing tube seat)
- Cascade easily removable, because without grease with integrated current limiting resistors
- Spring loaded contact between cascade and contact pin
- SuperCorona is easily dismantled and cleaned

4.1. Scope of delivery

- OptiGun 2-AE Automatic Powder Gun
Round jet nozzle with deflector plate
- Cable binder with Velcro closure
- Gun cleaning brush
- Parts set

4.2 Technical data - OptiGun 2-AE Automatic Powder Gun

Nominal input voltage:	10 V eff.
Nominal output voltage:	98 kV
Polarity:	Negative (option: Positive)
Max. output current:	100 microA
Cascade:	12 stages
Weight:	796 g (870 g with SuperCorona ring)
Flash protection:	Type A in accordance with EN 50177* /Type B

*Type A: The system corresponds to EN 50050:1986 with an energy limitation of 5 mJ. „The danger of an electric shock or explosive energy does not exist with these systems“.
Connection: The OptiGun 2-AE GA02 gun may only be connected to the OptiTronic control unit.

5. OptiGun 2-AE Automatic Powder Gun - Overview

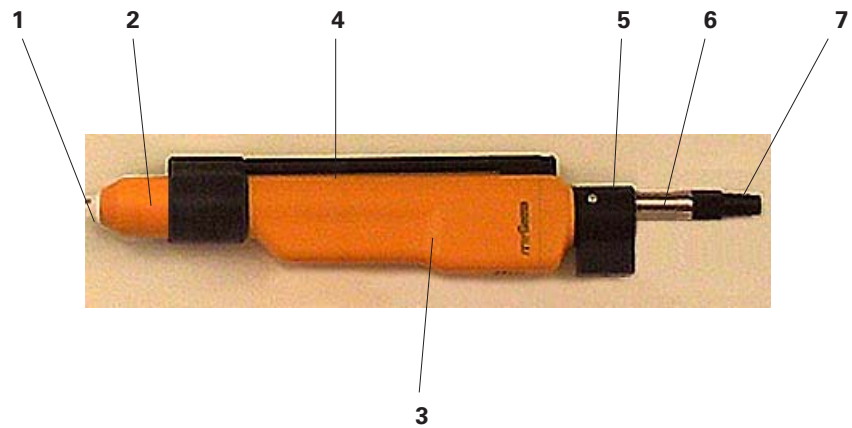

- | | | | |
|---|--------------------------------------|---|---------------------|
| 1 | Spray nozzle | 4 | SuperCorona ring |
| 2 | Threaded sleeve | 5 | Powder gun mounting |
| 3 | Shaft with removeable
H-v Cascade | 6 | Powder tube |
| | | 7 | Hose connection |

Fig. 1

5.1. Spray Nozzles

The OptiGun 2-AE Automatic Powder Gun can be equipped with the following spray nozzles. For more information see also „Nozzle combinations for OptiGun 2-AE“ in the Spare Parts List

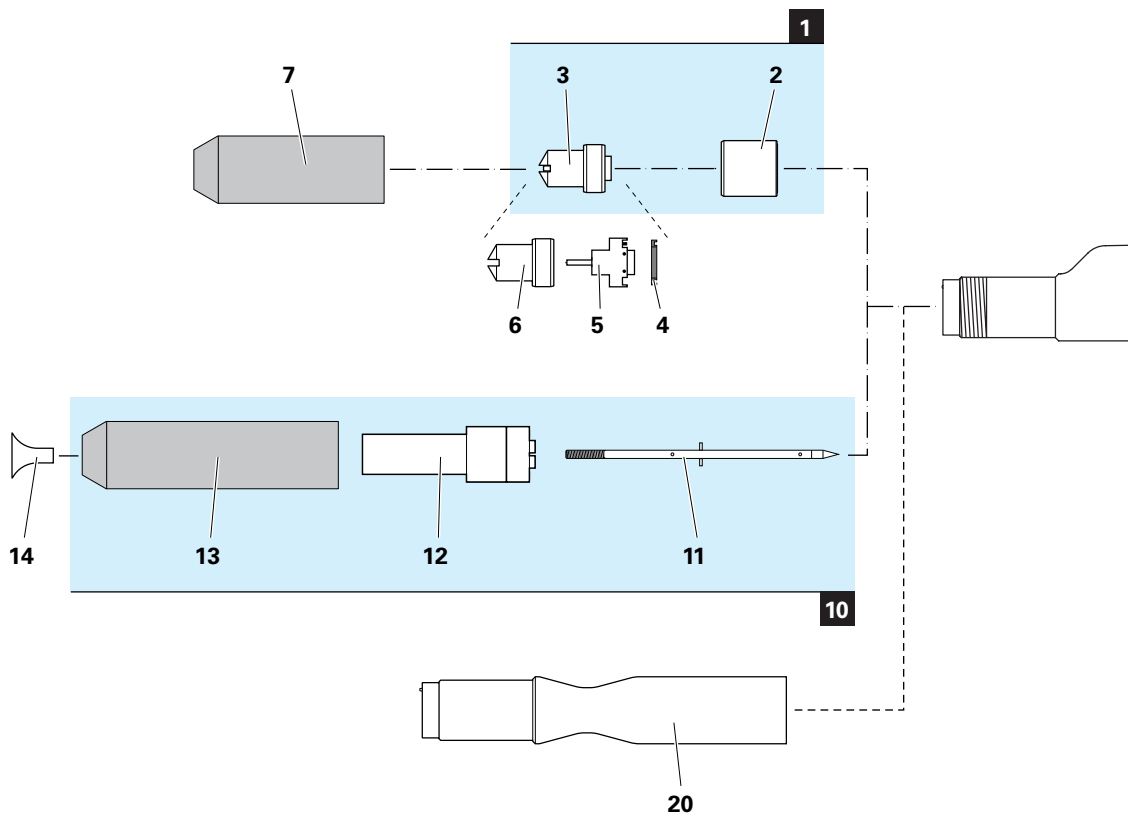

Fig. 2

5.2. High-voltage generation

The OptiTronic control module supplies high-frequency low-voltage of approximately 10 V_{eff}. This voltage is fed through the gun cable (**11**) and the gun connector to the high-voltage cascade (**4**).

In the cascade (**4**) this low voltage is stepped up (**c**). This primary high-voltage is subsequently rectified and multiplied in several stages in the cascade (**d**) until the required high voltage is attained.

The high-voltage is then fed from the spray nozzle to the electrode (**e**). See also Figs **5** and **6**.

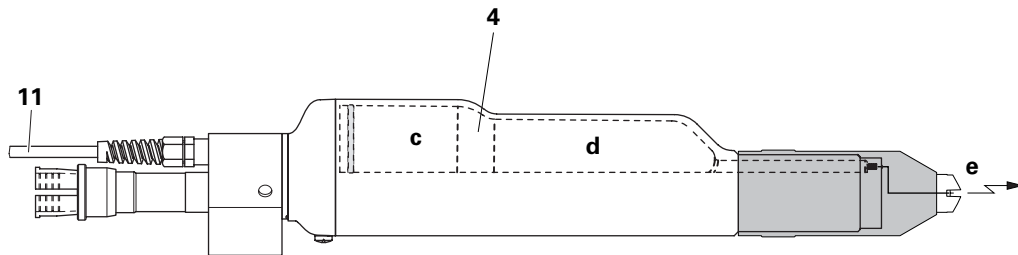

Fig. 3

5.3. Circuitry

The OptiGun 2-AE is switched on and off by the OptiTronic gun control module.

The control module switches the low-voltage, powder flow, and rinsing air to the gun.

5.4. Powder flow and rinsing air

The rinsing air used with the vented spray nozzle is connected with its designated connection on the rear of the control unit (see OptiTronic Powder Gun Control Operating Instructions).
Functioning of the spray nozzles is described in the corresponding paragraph (see page 8).

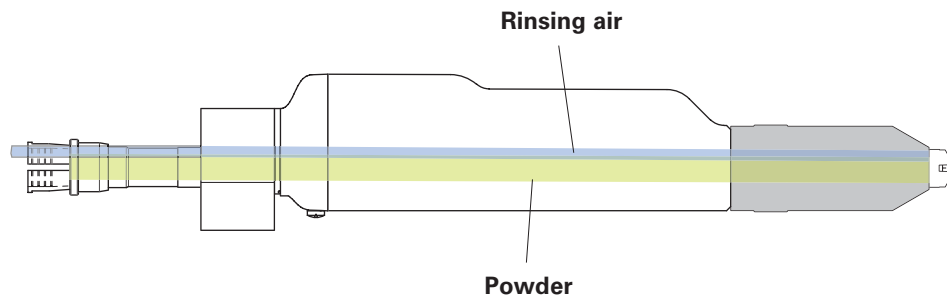

Fig. 4

5.5. Flat jet nozzle with vented central electrode

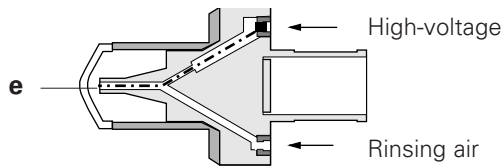

Fig. 5

The Flat jet nozzle serves to spray, and charge the powder. The powder cloud gets an oval spray pattern from the slot-shaped opening. The powder is charged by means of central electrode. The High-voltage, created in the gun by the cascade, is fed through the black contact ring of the nozzle holder to the central electrode. In order to prevent powder sintering on the electrode, this is rinsed with compressed air during spraying. In addition the rinsing air is fed through the small hole in the black contact ring of the nozzle holder into the electrode holder. Adjustment of the rinsing air on the control module is explained in the Operating Instructions of the control module.

5.6. Round jet nozzle with deflector and vented central electrode

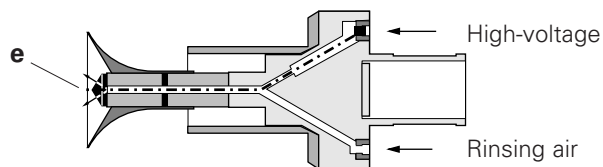

Fig. 6

In order to give to the powder stream emerging from the gun a shaped powder cloud, a deflector is used. The powder is charged by means of the central electrode. The High-voltage, which is created in the gun cascade, is conducted through the black contact ring of the nozzle holder to the central electrode. Since powder accumulates on the rear side of the deflector, this must be rinsed with compressed air. The rinsing air is fed through the small hole in the black contact ring of the nozzle holder into the electrode holder and is deflected in such a way that it flows over the surface of the deflector rear side. The strength of the rinsing air depends on the powder and its sintering ability. Adjustment of the rinsing air on the control module is explained in the Operating Instructions of the control module.

6. Preparation of the Start-up

6.1. Connect the OptiGun 2-AE Automatic Powder Gun

1. Connect the gun plug to the control unit (see OptiTronic control unit Operating Instructions).
2. Connect the rinsing air hose from the control unit to the gun.
3. Connect the powder hose of the gun to the injector.

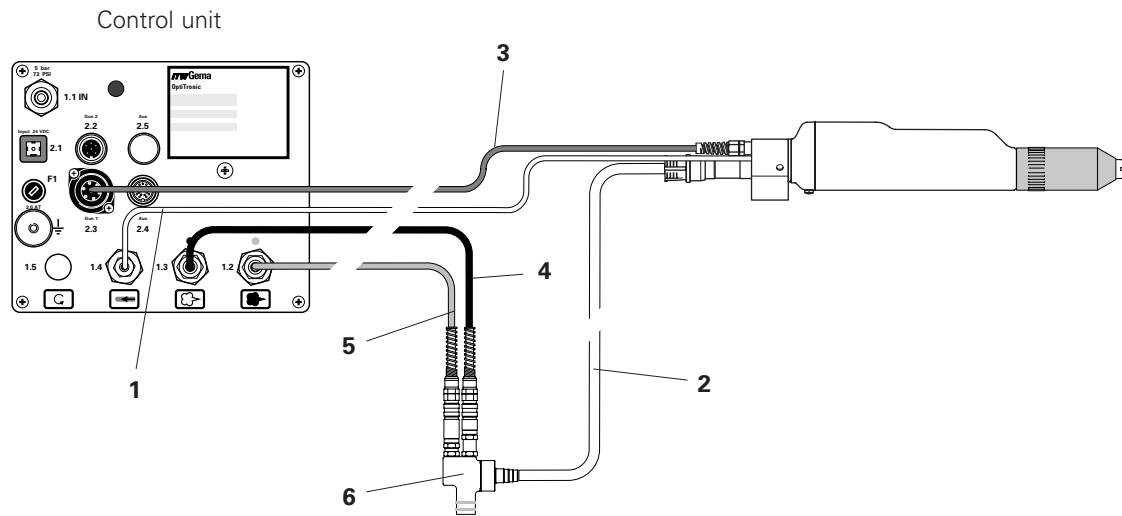

1 Rinsing air hose
 2 Powder hose
 3 Gun cable

4 Supplementary air hose
 5 Conveying air hose
 6 Injector

Fig. 7

6.2. Function check

In the case of possible faults see „Troubleshooting Guide“.

(For more information, see the the control unit Operating Instructions)

1. The fitted gun must be pointed at a grounded workpiece in the coating booth. All connections must be connected.
2. Switch on the powder gun control unit (see also the control unit Operating Instructions).
The gun starts spraying
3. Adjust the desired coating parameters (powder volume, total air, and high-voltage) on the control unit (see also the control unit Operating Instructions).
4. Set the rinsing air on the control unit dependent upon the nozzle used.

If all tests ran positive, the gun is ready for application. With a malfunction the cause of the fault can be located with the help of the Troubleshooting Guide page 23.

7. Start-up

7.1. Regulating the powder output and powder cloud

The powder output depends on the powder and the adjusted total air volume. (for more information, see OptiTronic Operating Instructions)

1. Start the powder gun control unit

7.2. Setting the Total air volume

2. Set the Total air volume

The total air volume is dependent on the powder tube length, and the number of hose curves, the hose diameter, the conveying air pressure and the supplementary air. The mode of operation of the injector and the effect of the supplementary air are described in the Operating Instructions of the injector used. The adjusted value of the total air volume can be left as it is, as long as the same diameter powder hose is used. If the hose diameter is changed the total air volume must be reset.

7.3. Selecting the powder output volume

3. Select the powder output volume for the desired layer thickness. Selection takes place with the help of the **+** or **-** keys or on the control unit. As a start, 60% is recommended as the standard adjustment. The total air volume is thereby kept constant automatically.
4. Check the fluidization of the powder
5. Move the gun into the booth and switch on the powder output (see OptiTronic Operating Instructions).

7.4. Selecting Electrode rinsing

6. Select the correct electrode rinsing (Adjustment range: 0 - 2.8 Nm³/h, default value: 0.2 Nm³/h)
7. Adapt the powder cloud to a test object
When using Flat jet nozzles:
 - Unscrew the threaded sleeve approx. 45 ° so that the Flat jet nozzle (or extension) can be moved slightly
 - Rotate the Flat jet nozzle to the desired axis angle
 - Firmly tighten the threaded sleeve againWhen using Round jet nozzles with air rinsed deflectors:
 - Exchange the deflector

7.5. Setting-up – Powder coating



CAUTION

Make sure that all electrically conductive parts are grounded within 5 m of the coating booth!

1. Check the fluidization of the powder.
2. The fitted gun must be pointed towards a grounded workpiece in the coating booth
3. Switch on the control unit.
4. Adjust the coating parameters or select one of the programs. Check by observing the LED displays.
5. The workpieces can be coated.

7.6. Shut-down

1. Switch off the powder gun control unit. The adjustments for High-voltage, rinsing air, and powder output remain stored.
2. For interruptions in working, such as lunch time, night, etc. the main air connection is to be switched off

7.7. Powder hose rinsing

By lengthy downtimes the powder hose is to be cleaned of powder. Proceed as follows:

1. Remove the powder hose from the hose connection on the injector (see the Operating Instructions of the injector used)
2. Blow the powder hose through with compressed air. Powder hose can be cleaned well by tearing off a foam cube from the packing material and blowing it through the hose with compressed air.
Use the ITW Gema air gun (**Order no. 346 055**), which was specially designed for this operation. The foam cube material can be ordered in sheets of 100 pieces, (**Order no. 241 717**).
3. Fit the powder hose to the hose connection on the injector again.

8. Maintenance plan



Regular and conscientious maintenance increases the service life of the gun and provides for a longer continuous coating quality!

8.1. Daily maintenance

- 1a Clean the gun, see below

8.2. Weekly maintenance

- 1b Clean the powder hopper, injector, and powder gun. Only fill the powder hopper before resumption of operation.
- 2b Check the grounding connections of the control module with the coating booth, the suspension devices of the workpieces, or the conveyor chain.

9. Cleaning and repairs

9.1. Cleaning

Frequent cleaning of the gun serves to guarantee the quality of the coating



Before cleaning the gun, switch off the control unit and the disconnect the gun plugs. The compressed air used for the cleaning must be free oil, and water.

9.1.1. Daily

- 1a Clean the gun, see below

9.1.2. Weekly

2. Remove the powder hose from the connection.
3. Remove the spray nozzle from the gun and clean.
4. Blow the gun through with compressed air from the connection in the direction of flow.
5. Clean the gun tube with the gun brush provided.
6. Blow the gun through with compressed air again.
7. Assemble the gun again and make the connections.
8. Clean the powder hose and blow through.



Make sure that the threaded sleeve is always tightened well. If the spray nozzle is only loosely fitted, the danger exists that the High-voltage of the gun can flash-over to the spray nozzle, which can inevitably lead to damage to the powder gun.

9.2. Dismantling the powder gun



The gun should only be dismantled if this is required because of a defect or pollution. It is only to be dismantled so far as the desired part is accessible. The control unit must be switched off and the gun plug detached before cleaning the gun.

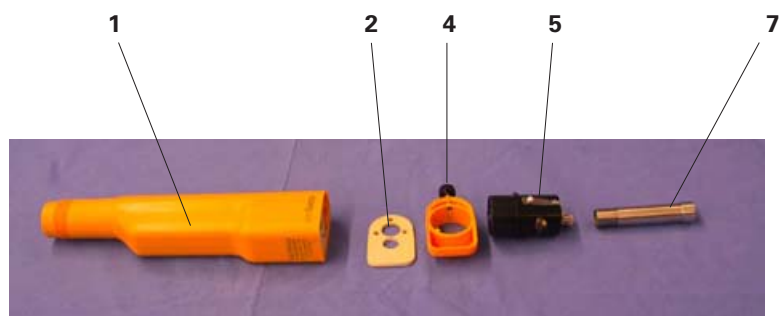

- 1 Shaft with removeable H-v cascade
- 2 Gasket

- 4 Intermediate piece
- 5 Connector
- 7 Hollow screw

Fig. 8

Dismantling the powder gun (cont.)



Fig. 9

Dismantling the powder gun (cont.)



Fig. 10

Dismantling the powder gun (cont.)



Fig. 11

Dismantling the powder gun (cont.)



Fig. 12

Dismantling the powder gun (cont.)



9.3. Powder gun re-assembly

- Re-assembling the gun is to be carried out in the reverse order to that shown above.
- Make sure that the powder tube is pushed in up to the stop.

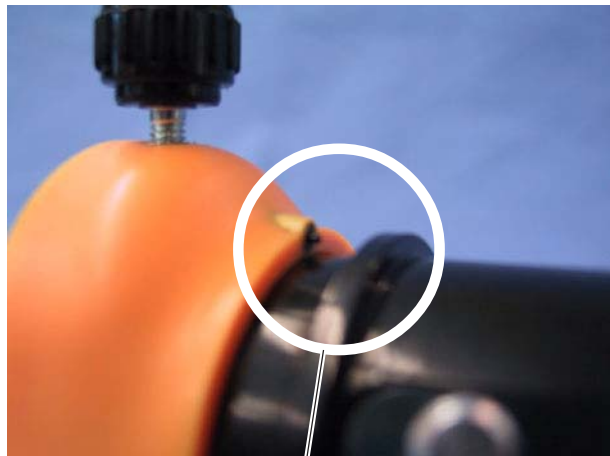

Make sure there is good contact!

Fig. 13

9.4. Repairs to the powder gun

Apart from the replacement of possibly defective parts, hardly any repairs have to be made. The cascade can be replaced trouble-free. Repair of the gun cable connection, however, may only be made by an authorized ITW Gema Service Center. Ask an ITW Gema agency.

9.5. Cleaning the spray nozzles

Daily or after each shift:

- Blow off the spray nozzles externally with compressed air. For cleaning the spray nozzles also solvents or other fluids can be used.

Only clean with a solvent soaked cloth, never immerse the parts in the solvent!

- Check the seating of the spray nozzles:



Make sure that the threaded sleeve is always tightened well. If the spray nozzle is only loosely fitted, the danger exists that the High-voltage of the gun can flash-over to the spray nozzle, which can inevitably lead to damage to the powder gun.

Weekly:

- Remove the spray nozzles and clean inside with compressed air: If sintering should have formed, then this is to be removed.

Monthly:

- Check the spray nozzles for abrasion:

The Flat jet nozzle is to be exchanged, if:

- the spray pattern is no longer a regular oval.
- deeper grooves in the nozzle slot or even the wall thickness is no longer visible
- the wedge of the electrode holder is worn down.

With nozzles with a deflector:

- if the wedge of the electrode holder is worn down, then the electrode holder is to be replaced

10. Troubleshooting Guide

For further fault descriptions see also the OptiTronic Operating Instructions, Section „Help code“.

Fault	Causes	Remedies
<p>The powder gun does not spray powder, although the powder gun control unit is switched on, the green lamp lights up and compressed air is available .</p>	<ul style="list-style-type: none"> - Injector, non-return valve or throttle in the injector, powder hose or powder gun clogged - Insert sleeve in the injector is worn - No fluidization <p>No conveying air:</p> <ul style="list-style-type: none"> - Pressure control valve in the OptiTronic defect - Solenoid valve in the OptiTronic defect - Electronics card in the OptiTronic defect 	<p>Clean or replace corresponding part</p> <p>Replace</p> <p>See OptiTronic Operating Instructions, PH Powder Hopper</p> <p>Replace</p> <p>Replace</p> <p>Send in for repair</p>
<p>Powder gun sprays powder, the powder, however, does not adhere to the workpiece.</p>	<ul style="list-style-type: none"> - Too low or no high-voltage - Powder gun cables (powder gun plug or powder gun connection) defect - High-voltage cascade defect - Electronics board in control defect 	<p>Increase High-voltage on the control</p> <p>Test powder gun cables on another OptiTronic</p> <p>Send powder gun shaft in for repair</p> <p>Send in for repair</p>
<p>Powder gun sprays powder, High-voltage available, powder does not adhere to the workpiece.</p>	<ul style="list-style-type: none"> - Workpiece not properly grounded. 	<p>Check grounding. See also Operating Instructions Section 1</p>

NOTES:

11. Spare Parts List

11.1. Ordering spare parts

When ordering Spare parts for powder coating equipment, please indicate the following specifications:

1. Type and serial number of your powder coating equipment
2. Order number, quantity, and description of each spare part

Example:

1. Type OptiGun 2-AE, **Serial No.:** XXX XXX

2. Order No.: 382698, 1 piece, Gasket

When ordering cable and hose material the length required must be given.

The spare part numbers of yard/meter ware always begins with **1.. ...** and are always marked with an ***** in the spare parts list.

Wear parts are always marked with a **#**.

All dimensions for plastic powder hoses are given as external diameter (o/d) and internal diameter (i/d):

e. g. \varnothing 8 / 6 mm, 8 mm outside diameter / 6 mm inside diameter (i/d).

11.2. OptiGun 2-AE Automatic Powder Gun

Remarks:

- Only parts are included in the spare parts list, which the user can replace himself without problems.
- If the powder gun cable (**4**) is defective, then it is to be sent in complete for repair.

11.3. OptiGun 2-AE Automatic Powder Gun - complete

OptiGun 2-AE Automatic Powder Gun - complete Polarity – (negative), including Items 1 - 6 ,	406511
1 Powder gun body - OptiGun 2-AE - complete Polarity – (negative), see also Section 11.4.	406503
2 Round jet nozzle complete - see also Section 11.7.	405752#
2.1 Deflector plate - ø 28 mm	400254#
3 Threaded sleeve - see also Section 11.7.	405728
4 Powder gun cables - 20 m - complete - see also Section 11.6.	393827
5 Parts set (not shown) consisting of:	385670
- Cable binder with Velcro closure (8x)	303070
- Screw - M8 x 50 mm	235113
- Pan-Head plastic screw M4x6 mm	267139
- Washer - ø 8.4 / 20 x 2 mm	215880
- Quick coupling - NW5 - ø 6 mm	200840
6 Cleaning brush – ø 12 mm (not shown)	389765
7 Powder hose – ø 16 / 11 mm (not shown)	103012*
8 Rinsing air hose – ø 6 / 4 mm (not shown)	100854*

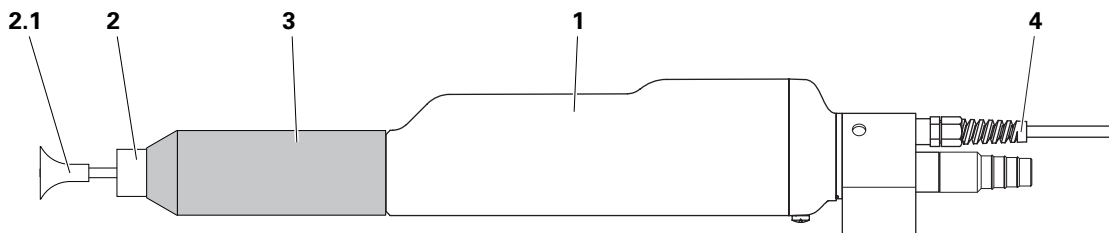

* Please indicate length required

Wear parts

Fig. 14

11.4. Powder gun body OptiGun 2-AE - complete

Powder gun body - OptiGun 2-AE - complete	406503
Polarity – (negative)	
1 Shaft - OptiGun-A - complete	393665
Polarity – (negative), see also Section 11.5.	
2 Powder tube - complete	405698#
3 Powder gun mounting	382817

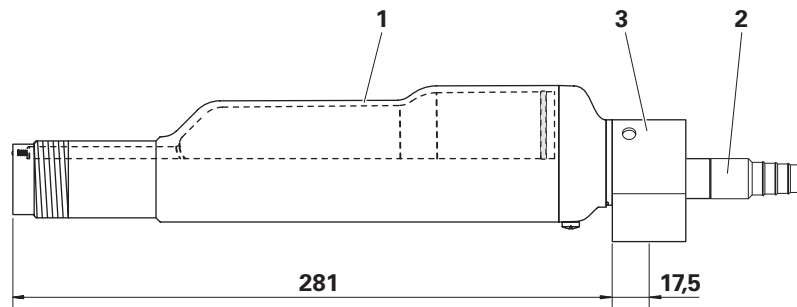
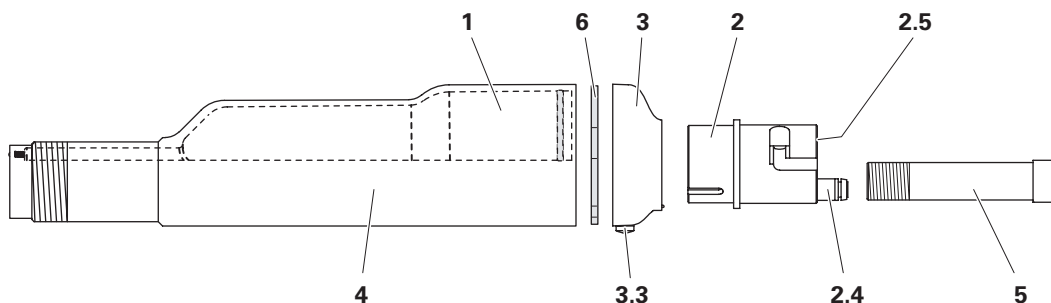

Fig. 15

11.5. Shaft OptiGun 2-AE - complete

Shaft - OptiGun-A - complete	393665
Polarity – (negative)	
1 Cascade - complete - negative	393703
2 Connector - complete including Items 2.4 and 2.5	385158
2.4 Adaptor - 1/8"-ø 6 mm	251542
2.5 Plug - 1/8"	265560
3 Adapter complete including Item 3.3	385069
3.3 Screw - M4 x 5 mm	216763
4 Shaft (without cascade)	393681
5 Hollow bolt	382680
6 Gasket	382698



* Please indicate length required
 # Wear parts

Fig. 16

11.6. Powder gun cable - complete

	Powder gun cable - complete - 11 m	393800
	Powder gun cable - complete - 15 m	393819
	Powder gun cable - complete - 20 m	393827
9	Cover	360317
11	Screw - M2 x 4 mm	257958
12	Screw - M5 x 6 mm	263907
13	O Ring - \varnothing 10.82 x 1.78 mm	232556
14	O Ring - \varnothing 7.65 x 1.78 mm	232564
15	O Ring - \varnothing 8.10 x 1.6 mm	263818
21	Gland - PG07 with kink protection	208426
22	Cable – 3 x 0.75 mm ² - shielded	104892*
23	Plug - 7 pins	200085

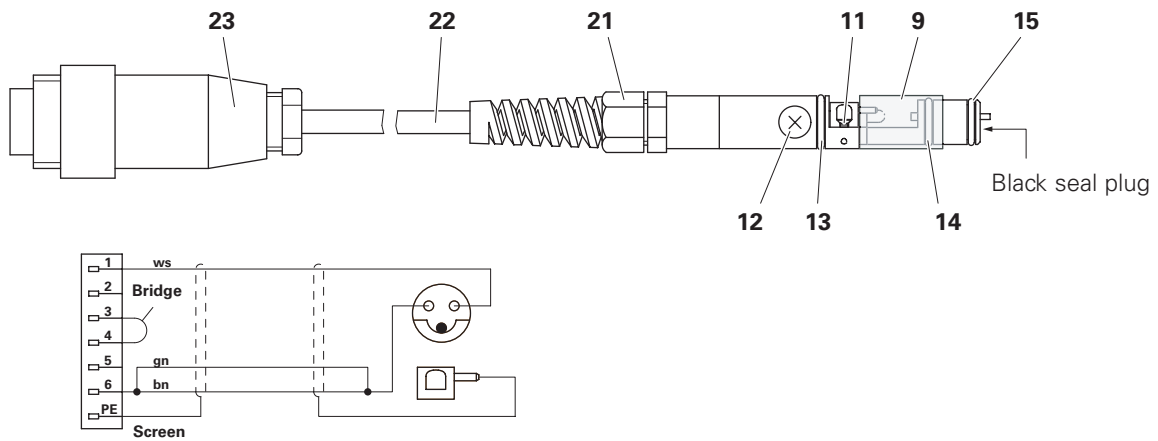

bn = brown
gn = green
ws = white

* Please indicate length

Wear parts

Fig. 17

11.7 Nozzle combinations for OptiGun 2-AE

1	Flat Jet Nozzle - NF05-E	405744#
2	Adapter piece - complete	406023#
3	FSD Nozzle set (without Item 5.1)	404225#
4	Contact ring	318760#
5	Electrode holder - Tefzel - complete	404209#
5.1	Electrode holder - Teflon - complete	406058#
6	Flat Jet Nozzle	404128#
7	Threaded sleeve - PU04-E-NF	405728#
10	Round Jet Nozzle - NS03-E - complete	405752#
11	Deflector plate rod - complete	405582#
12	Nozzle - complete	405949#
13	Threaded sleeve - PU04-E-NS	405736
14	Deflector plate - ø 15 mm	400262#
14.1	Deflector plate - ø 24 mm	400181#
14.2	Deflector plate - ø 28 mm	400254#
14.3	Deflector plate - ø 30 mm	400238#
14.4	Deflector plate - ø 50 mm	400246#
20	Extension - 150 mm	405922#
20.1	Extension - 300 mm	405930#

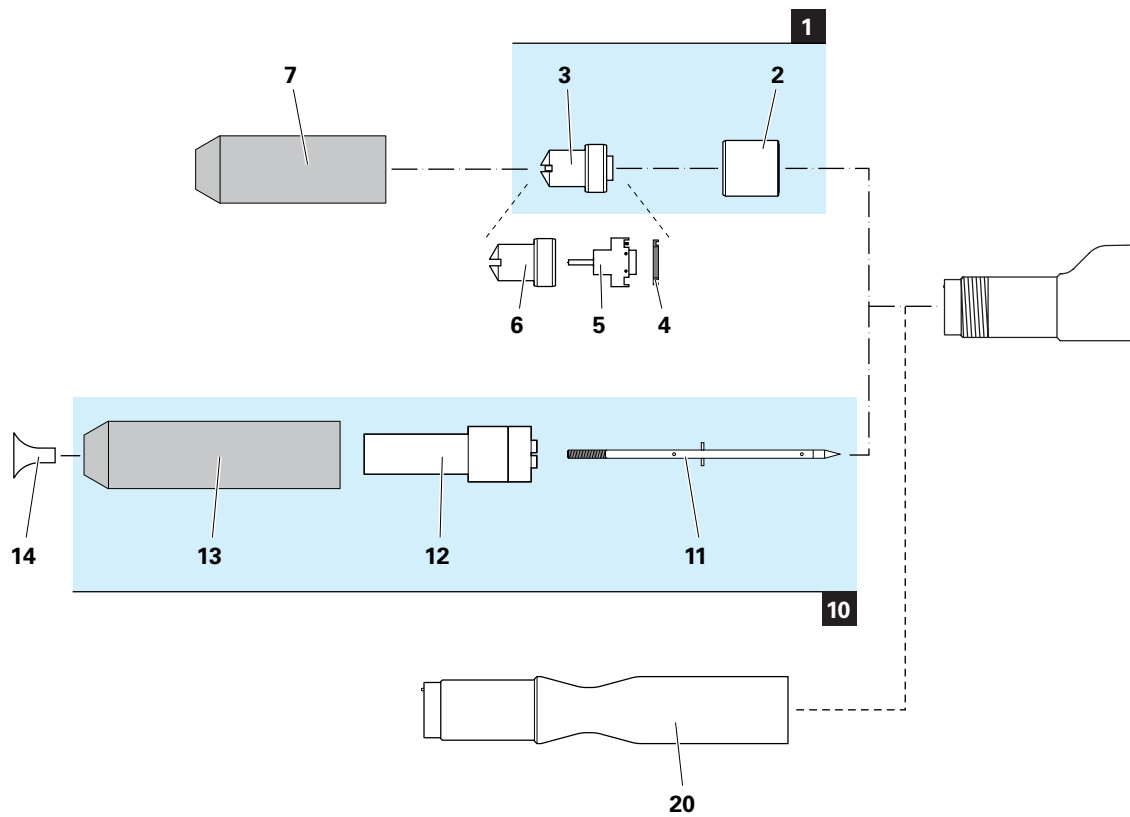

* Please indicate length

Wear parts

Fig. 18

11.8. Nozzle combinations for OptiGun 2-AE - Angled Nozzle

Angled Nozzle - PA01-E-60° - complete	405760#
1 Clamp ring - small	405876
2 Elbow piece	383490
3 FSD Nozzle set (without Item 5.1)	404225#
4 Contact ring	318760#
5 Electrode holder - Tefzel - complete	404209#
5.1 Electrode holder - Teflon - complete	406058#
6 Flat Jet Nozzle	404128#
7 Holding ring	383619
8 Sleeve	383627
9 Clamp ring - large	383597
10 Hood	383732

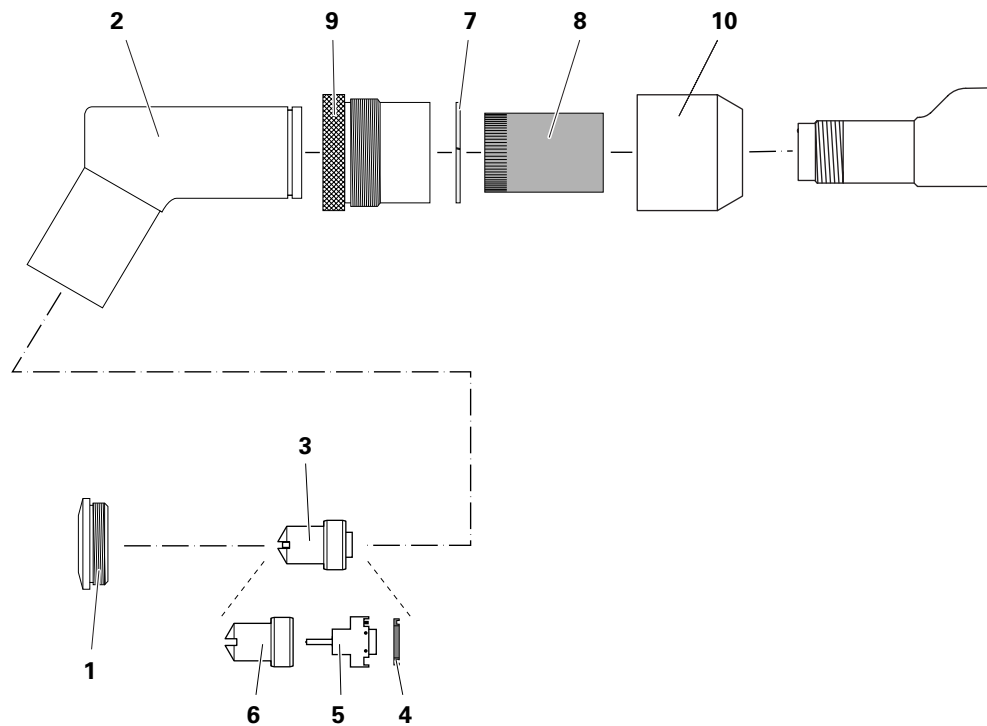

Wear parts

Fig. 19

11.9. OptiGun 2-AE - SuperCorona

	SuperCorona - complete	385174#
1	Ring - complete	391980#
5	Special screw	391921
6	Adapter	384372
7	Spring - 0.40 x 2.0 x 10.9 mm	245330

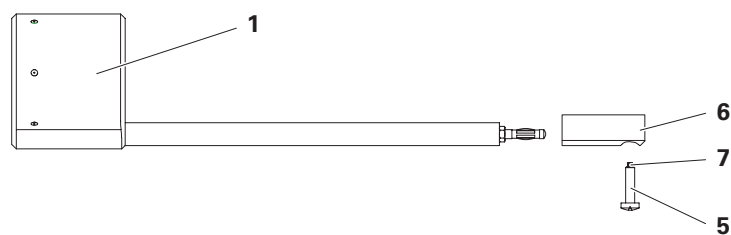

Wear parts

Fig. 20

DOCUMENTATION OPTIGUN

© Copyright 2000 ITW Gema AG
All rights reserved.

This publication is protected by copyright. Unauthorized copying is prohibited by law. No part of this publication may be reproduced, photocopied, translated, stored on a retrieval system or transmitted in any form or by any means, for any purpose, neither as a whole nor partially, without the express written consent of ITW Gema AG.

OptiTronic, OptiGun, EasyTronic, EasySelect, EasyFlow and SuperCorna are registered trademarks of ITW Gema AG. OptiMatic, OptiMove, OptiMaster, OptiPlus, OptiMulti and Gematic are trademarks of ITW Gema AG.

All other product names are trademarks or registered trademarks of their respective holders.

Reference is made in this manual to different trademarks or registered trademarks. Such references do not mean that the manufacturers concerned approve of or are bound in any form by this manual. We have endeavoured to retain the preferred spelling of the trademarks, and registered trademarks of the copyright holders.

To the best of our knowledge and belief, the information contained in this publication was correct and valid on the date of issue. ITW Gema AG makes no representations or warranties with respect to the contents or use of this publication, and reserves the right to revise this publication and make changes to its content without prior notice.

Printed in Switzerland

ITW Gema AG
Mövenstrasse 17
9015 St. Gall
Switzerland

Phone: +41-71-313 83 00
Fax: +41-71-313 83 83
E-mail: info@itwgema.ch
Home page: www.itwgema.ch