

Table of Contents

Safety Recommendations

1. ACR Reciprocator	2
1.1 Field of application	2
1.2 Operating mode	2
1.3 Technical data	4
1.4 Preparation for start-up	4
1.5 Assembling the spray gun carrier and handrail	5
2. Reciprocator maintenance	6
2.1 Placing the reciprocator on trestles	7
2.2 Replacing the drive chain	8
2.3 Replacing the upper sprocket and pedestal bearing	9
2.4 Replacing the lower sprocket	9
2.5 Replacing the plastic tension pads	10
2.6 Replacing the counterweight rollers	10
2.7 Tensioning the drive chain	10
2.8 Replacing the Z Carriage	12
2.9 Replacing the carriage rollers	12
2.10 Adjusting the carriage rollers	13
2.11 Replacing the drive unit	14
2.12 Replacing the incremental pulse generator	14

Spare Parts List

1. ACR Reciprocator

1.1 Field of application

Objects are coated with powder with the aid of the ACR Reciprocator controlled by a PRC (or an MRC) control unit.

Objects are electro-statically coated with powder as they move horizontally on a chain conveyor system past spray guns moving automatically up and down on the ACR Reciprocator.

1.2 Operating mode

The Z Carriage (**4**) runs up and down on rollers (**5**) on the outside of the column (**9**) and the counterweight (**12**) moves up and down on the inside of the column. Depending on the number of guns (normally for 5 guns or more), twice the weight is required for the counterweight.

The Z Carriage (**4**) and the counterweight (**12**) are connected to the drive chain (**10**). This drive chain (**10**) leads from the reversing plate (**11**) sprocket and is driven by the sprocket of the drive motor.

The drive unit (**2**) consists of an AC motor, a worm gear drive, and an incremental pulse generator which transmits the spindle position to the PRC (or MRC) unit.

Speeds, dwell time at the reversing points, and the positions of the reversal points are determined in the PRC (or MRC) Control unit.

Key to the diagram opposite :

- 1 Base
- 2 Drive
- 3 Hose carrier
- 4 Z Carriage
- 5 Roller
- 6 Gun carrier
- 7 Gun
- 8 Panelling
- 9 Column
- 10 Chain
- 11 Reversing plate
- 12 Counterweight
- 13 Service panel
- 14 Support bracket
- 15 T-Clamp block - $\varnothing 30 / \varnothing 30$ mm
- 16 Tube - $\varnothing 30 \times 600$ mm
- 17 Tube - $\varnothing 30 \times 1000$ mm
- 18 Rubber strap

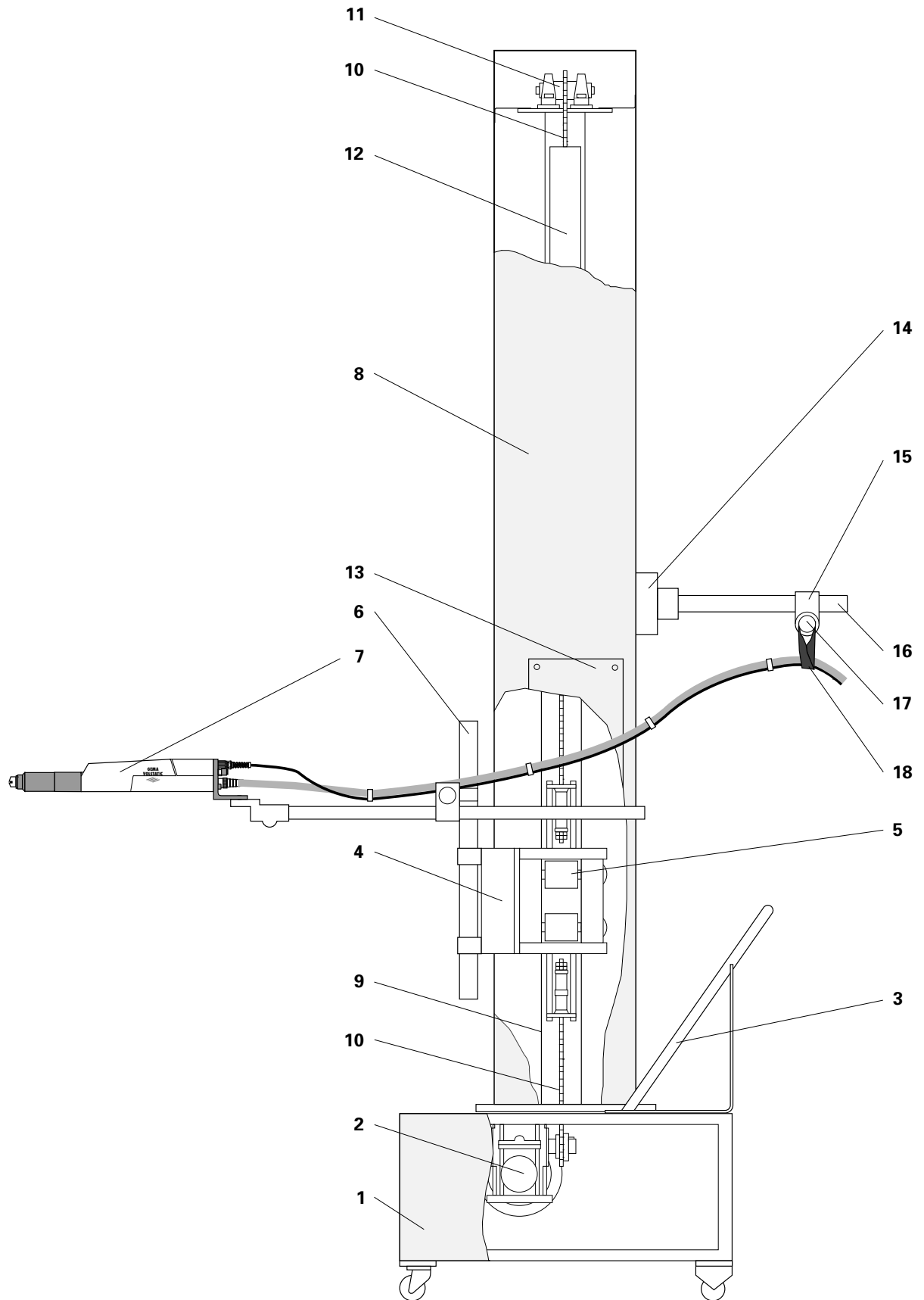

Figure 1

1.3 Technical Data

Single Phase AC :	220 V (with Transformer 110 V / 240 V) 50 / 60 Hz 1.1 kVA
Power requirement :	220 V (with Transformer 110 V / 240 V) 50 / 60 Hz 1.5 kVA
Tolerance :	+10% / -15%
Protective system :	IP 54
Temperature range for the whole installation :	10 °C to +40 °C (50 °F to +104 °F) ambient temperature

Type of reciprocator	2/06/30					
Stroke adjustment from : Min.	0.1 m	4 in				
to : Max.	0.6 m	24 in				
Stroke speed adjustment from :	0.05 m/s	10 ft/m				
to :	0.60 m/s	118 ft/m				
Dwell time at the reversing points Adjustable from :	0.0	0.0				
to :	25.5 s	25.5 s				
Counterweight	30 kg	66 lbs				
Maximum load of the Z Carriage	30 kg	66 lbs				
Height of reciprocator	3.4 m	8'-4"				

1.4 Preparation for start-up

1. Fit the handrail (Page 5).
2. Set the Main switch to **0** and connect the cable of the reciprocator and the PRC (or MRC).
3. Set the reciprocator in operation according to the PRC (or MRC) Operating Instruction.

 **CAUTION**

The gun slot must be at least 150 mm (6 in) higher than the upper reversing point and 150 mm (6 in) lower than the lower reversing point, otherwise reduce the maximum stroke (see PRC or MRC Operating Instructions).

1.5 Assembling the spray gun carrier and handrail

1. Slide the Z Carriage **(4)** to the lower stop **(14)**.
2. Assemble the tube holders **(15)** on the Z Carriage **(4)**.
3. Assemble both vertical tubes **(16)**.
4. Mount the T-clamp blocks **(17)** on the vertical tubes **(16)**.
5. Slide the horizontal tubes **(18)** through the T-clamp blocks **(17)**.
6. Fit the T-clamp block **(57)** on the horizontal support tubes **(18)**.
7. Slide the gun tube(s) **(20)** into the T-clamp block **(57)** and lock.
8. Mount the spray gunholder tube **(20)** on the adjustable clamp plate **(19)**.
9. Fit the automatic gun(s) **(7)** on the adjustable clamp plate **(19)**.
10. Screw on the handrail **(3)**.

Figure 2

2. Reciprocator maintenace

Blow off the outside of the reciprocator with compressed air or wipe down with a soft cloth once every week.

Service : *Annually* - when working single shift (Normal operation).

Half yearly - when working three shifts.

Page

The following checks and maintenance work are to be carried out :

- | | |
|--|--------|
| 1. Start-up the reciprocator and check the Z Carriage for quiet running. | |
| • The drive chain touches the column (metallic noise). | |
| – Replace the plastic tension pads or re-tension the drive chain. | 10 |
| • Strong vibration on the guns. Carriage has play. | |
| – Adjust the rollers. | 13 |
| 2. Dismantle and clean the gun and handrail. | 5 |
| 3. Dismantle and clean the reciprocator column panels. | ETL 2 |
| 4. Replace the rubber strips if badly worn. | ETL 2 |
| 5. Check the drive chain, replace when necessary. | 8 |
| 6. Check sprockets and pedestal bearings, replace when necessary. | 9 |
| 7. Check the counterweight rollers, replace when necessary. | 10 |
| 8. Check the carriage rollers, replace when necessary. | 12, 13 |
| 9. Thoroughly tighten all screws and nuts. | |
| 10. Assemble the reciprocator panels | ETL 2 |
| 11. Grease the drive chain with normal lubricating grease. | |

2.1. Placing the reciprocator on trestles

1. Remove the handrail (**3** - Fig. 1).
2. Unscrew the gun carriers (**6** - Fig. 1).
3. Remove the column panels (**8** - Fig. 1).
4. Tilt the reciprocator on wooden blocks and lay it on trestles.

Figure 3

2.2 Replacing the drive chain

Always replace the drive chains, and sprockets at the same time !

1. Tilt the reciprocator on wooden blocks and lay it on trestles, see Page 7.
2. Loosen the nuts (**21** - Fig. 8) of both plastic tension pads (**22/22a** - Fig. 8) = Tension the drive chain (**10**) and drive chain (**10a**).
3. Remove the connecting links (**24** - Fig. 8) between the drive chain (**10**) and the tensioning bolt (**33** - Fig. 8) = Drive chain (**10**) released.
4. Unscrew the reversing plate (**11**) and fit a new sprocket, see Page 9.
5. Remove the counterweight (**12**) and drive chain (**10**).
6. Release the connecting link (**27** - Fig. 7) of the chains (**10/10a**) from the counterweight (**12**), see page 11.
7. Pass a wire through the column (**9**).
8. Fix the new drive chain (**10**) to the wire and pull it through the column (**9**).
9. Fit the other end of the drive chain to the counterweight (**12**).
10. Fit the reversing drive chain to the counterweight (**12**) and pass the drive chain with the counterweight into the column.
11. Fit the drive chain (**10**) on the tensioning bolt (**33** - Fig. 8).
12. Screw the reversing plate (**11**) in to place.
13. Fit both chains (**10/10a**) on to the sprockets (**26/28**).
14. Fit the end of the reversing chain (**10a**) to the upper tensioning bolt (**33** - Fig. 8).
15. Tighten the nuts (**21** - Fig. 8) of both plastic tension pads (**22/22a**) until both chains (**10/10a**) can no longer be pressed on to the column (**9**) with the hand.

Figure 4

2.3 Replacing the upper sprocket and pedestal bearing

1. Tilt the reciprocator on wooden blocks and lay it on trestles, see page 7.
2. Loosen the nuts (**21** - Fig. 9) of both plastic tension pads (**22/22a** - Fig. 9) = Tension of the drive chain (**10** - Fig. 4) and drive chain (**10a** - Fig. 4) is released.
3. Remove the connecting links (**24** - Fig. 8) between the drive chain (**10** - Fig. 4) and the tensioning bolt (**33** - Fig. 8) = Drive chain (**10** - Fig. 4) released.
4. Loosen the screws (**43**).
5. Unscrew the Allen grub screw (**47**) with an Allen key.
6. Release the collar (**44**) with a hammer and punch (**46**).
7. Remove the collar (**44**) from the end of the shaft.
8. Remove both pedestal bearings from the old sprocket and fit the new sprocket.
9. Align the sprocket correctly on the reversing plate (**59**) and screw the four bolts (**43**) tight.
10. Slide the collar (**44**) over the end of the shaft and tighten with the hammer and punch (**46**). Secure the grub screw (**47**).
11. Fit the drive chain (**10a** - Fig. 4) onto the sprocket (**26** - Fig. 4).
12. Fit the drive chain (**10a** - Fig. 4) on the upper plastic tension pad (**22a** - Fig. 9).
13. Tighten the nuts (**21** - Fig. 9) of both plastic tension pads (**22/22a** - Fig. 9) until the drive chains (**10/10a** - Fig. 4) can no longer be pressed onto the column (**9** - Fig. 4) with the hand.

Figure 5

2.4 Replacing the lower sprocket

1. Remove the sprocket with the aid of a bearing extractor or have it removed by trained personnel.

2.5 Replacing the plastic tension pads

1. Tilt the reciprocator on wooden blocks and lay it on trestles, see page 7.
2. Loosen the nuts (**21** - Fig. 9) of both plastic tension pads (**22/22a** - Fig. 6) = Tension of the drive chain (**10/10a** - Fig. 4) is released.
3. Remove the tension bolt (**33** - Fig. 9) and the old plastic tension pads (**22/22a** - Fig. 6) and replace the pads
4. Slide the tension bolt (**33** - Fig.9) into the new pads.
5. Tighten the nuts (**21** - Fig. 6) of both plastic tension pads (**22/22a** - Fig. 6) until the drive chain (**10/10a** - Fig. 4) can no longer be pressed onto the column (**9** - Fig. 8) by hand.

2.6 Replacing the counterweight rollers

1. Tilt the reciprocator on wooden blocks and lay it on trestles, see page 7.
2. Loosen the nuts (**21** - Fig. 9) of both plastic tension pads (**22/22a** - Fig. 9) = Tension of the drive chain (**10/10a** - Fig. 4) is released.
3. Dismantle the reversing plate (**59** - Fig. 5). Loosen the screws (**43** - Fig. 5). See page 9.
4. Remove the connecting link (**24** - Fig. 8) between the lower plastic tension pads (**22** - Fig. 8) and the drive chain (**23** - Fig. 8).
5. Fit a wire to the loose end the drive chain (**23** - Fig. 8) to prevent it from falling inside the column.
6. Remove the counterweight (**12** - Fig. 7) from the column (**9** - Fig.7).
7. Replace the worn rollers (**34** - Fig. 6).
 1. Remove the shoulder screw (**35** - Fig. 6).
 2. Replace the roller (**34** - Fig. 6).
 3. Refit the shoulder screw (**35** - Fig. 6).
8. Slide the counterweight (**12** - Fig. 7) into the column.
9. Pull the drive chain (**23** - Fig. 8) out with the aid of a wire.
10. Refit the reversing plate (**59** - Fig. 5). Tighten the screws (**43** - Fig. 5), see page 9.
11. Fit the chain onto the sprockets (**26/28** - Fig. 4).
12. Connect the drive chain (**23** - Fig. 8) to the plastic tension pads (**22** - Fig. 8).
13. Tighten the nuts (**21** - Fig. 9) of both plastic tension pads (**22/22a** - Fig. 9) until the drive chain (**10/10a** - Fig. 4) can no longer be pressed onto the column (**9** - Fig. 4) by hand.

2.7 Tensioning the drive chain

1. Open the service panel (**13** - Fig. 1) in order to tighten the nuts (**21** - Fig. 9) of the plastic tension pads (**22/22a** - Fig. 9).

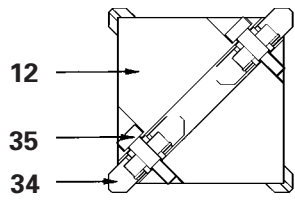

Figure 6

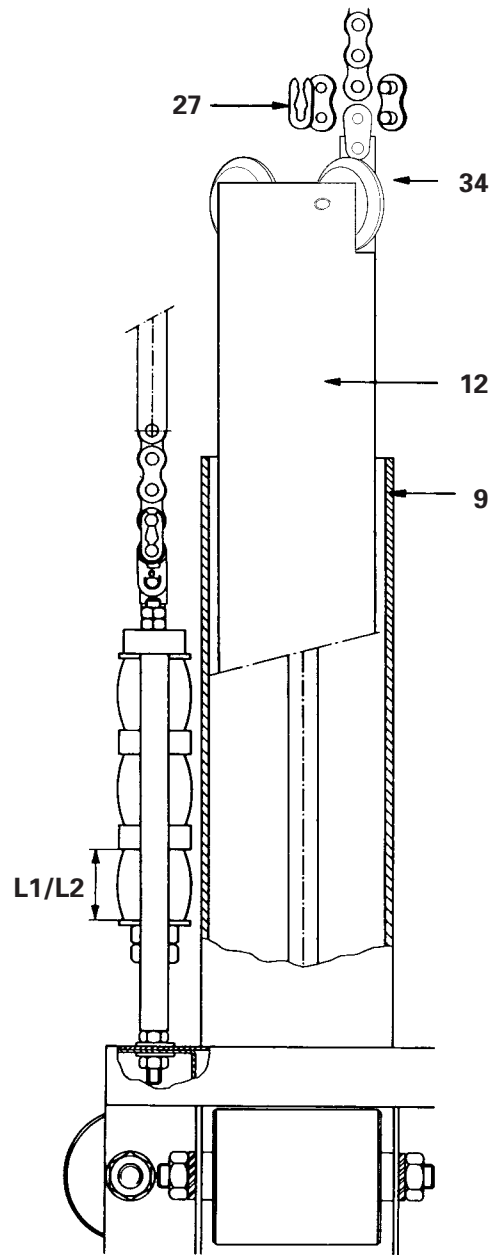

Figure 7

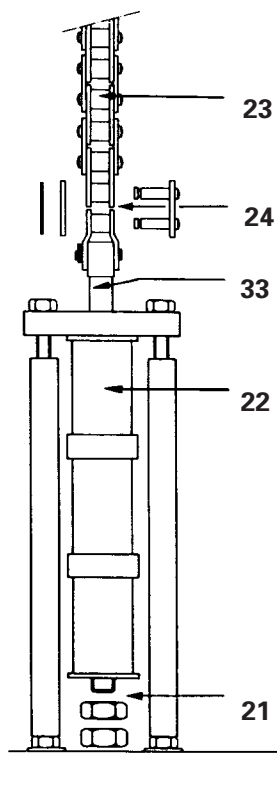

Figure 8

L 1 = First tension to 33 mm (1 5/16")

L 2 = Then tension to 30 mm (1 3/16")

2.8 Replacing the Z Carriage

1. Tilt the reciprocator on wooden blocks and lay it on trestles, see page 7.
2. Loosen the nuts (**21** - Fig. 9) of both plastic tension pads (**22/22a** - Fig. 9) = Tension of the drive chains (**10/10a** - Fig. 4) is released.
3. Unscrew the reversing plate (**59** - Fig. 5), see page 9.
4. Remove the upper stop (**14a** - Fig. 4).
5. Remove the connecting links (**24** - Fig. 8) between the plastic tension pads (**22** - Fig. 8) and the drive chain (**10/10a** - Fig. 4) = Upper and lower drive chains (**10/10a** - Fig. 4) released.
6. Run out the Z Carriage (**4**).
7. Dismantle both plastic tension pads (**22/22a** - Fig. 9) by loosening the nuts (**37** - Fig. 9) and fit to the Z Carriage (**4**).
8. Dismantle the cover plate (**23** - Fig. 9) and fit to the new Z Carriage (**4**).
9. Slide the new Z Carriage (**4** - Fig. 9) on to the column (**9** - Fig. 4).
10. Fit the upper stop (**14a** - Fig. 4) and the reversing plate (**11** - Fig. 4).
11. Place the drive chain on the sprocket (**26** - Fig. 5).
12. Fit the drive chain on to the plastic tension pads again.
13. Tighten the nuts (**21** - Fig. 9) of both plastic tension pads (**22/22a** - Fig. 9) until the drive chain (**10/10a** - Fig. 4) can no longer be pressed onto the column (**9** - Fig. 4).

2.9 Replacing the carriage rollers

1. Tilt the reciprocator on wooden blocks and lay it on trestles, see page 7.
2. Remove the cover plate (**23** - Fig. 9)
3. Loosen the nuts (**21** - Fig. 9) of both plastic tension pads (**22/22a** - Fig. 9) = Releases the tension on the drive chain (**10** - Fig. 4) and drive chain (**10a** - Fig. 4).
4. Loosen the locking nuts (**39** - Fig. 9) and screw out the locking screws (**41** - Fig. 9) until the roller can be moved freely.
5. Unscrew the nut (**36** - Fig. 9) completely from the roller spindle bolt (**32** - Fig. 9) and pull the bolt out of the roller.
6. Remove the roller (**5** - Fig. 9) from the Z-carriage body. Take care not to lose the spacing sleeves (**40** - Fig. 9).
7. Replace with a new complete roller with the spacing sleeves (**40** - Fig. 9) in place on each side of the roller.
8. Push the roller spindle bolt (**32** - Fig. 9) through the roller and screw on the nut (**36** - Fig. 9).
9. Adjust the rollers according to the next section "2.10 Adjusting the carriage rollers - Points 3-8".
10. Tension the drive chains as follows :
Tighten the nuts (**21** - Fig. 9) of both plastic tension pads (**22/22a** - Fig. 9) until the drive chain (**10/10a** - Fig. 4) can no longer be pressed onto the column (**9** - Fig. 4).

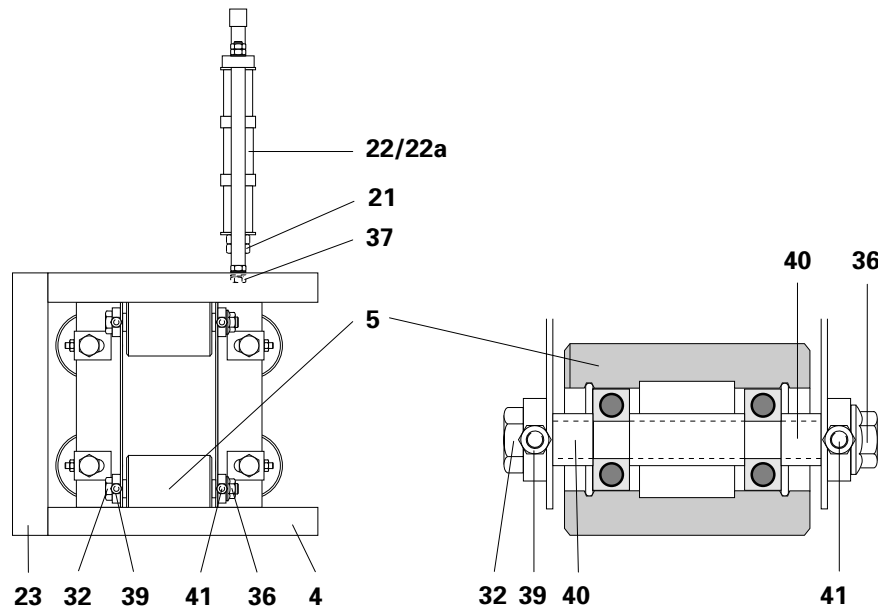

Figure 9

2.10 Adjusting the carriage rollers

1. Loosen the nut (**36** - Fig. 10) slightly.
2. Loosen the locking nut (**39** - Fig. 10).
3. Turn both locking screws (**41** - Fig. 10) equally in a clock-wise direction with corresponding Allen keys.
4. The roller (**5** - Fig. 10) moves against the column (**9** - Fig. 10) until it rests flat on the column.

Attention : It should not be possible to turn the roller manually.

5. Tighten both locking nuts (**39** - Fig. 10) firmly on each side of the roller (**5** - Fig. 10).
6. Firmly tighten the nut (**36** - Fig. 10) at the side of the roller (**5** - Fig. 10), use a second spanner to hold the roller spindle bolt (**32** - Fig. 10).
7. Adjust the remaining rollers (**5** - Fig. 10) according to the Points 1-6 above.
8. **Z Carriage must roll freely the whole length of the stroke without any play.**

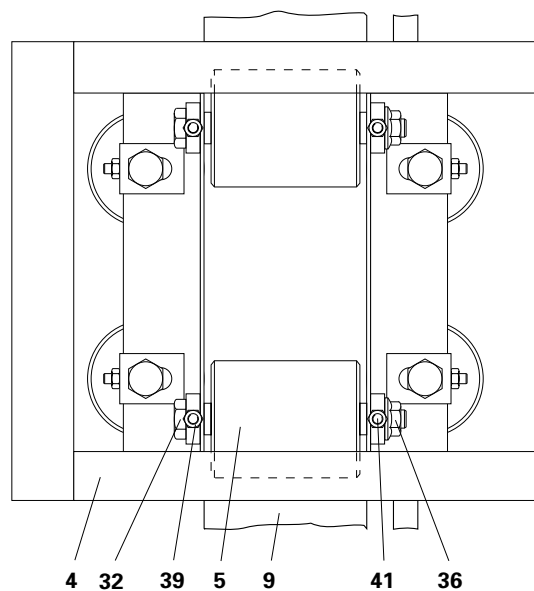

Figure 10

2.11 Replacing the drive unit

1. Tilt the reciprocator on wooden blocks and lay it on the trestles. See page 7.
2. Release the drive chain (10) from the plastic tension pads (22 - Fig. 9).
3. Loosen the four screws (58) on the base plate and replace the complete drive (2).
4. Fit the new drive unit and connect the incremental pulse generator.
5. Tighten the base plate screws (58).
6. Tension the lower drive chain.

2.12 Replacing the incremental pulse generator

 **CAUTION**

**When disconnecting the incremental pulse generator cable, note the exact positions of the wires in the terminal and replace the wires of the new incremental pulse generator accordingly.
DANGER OF SHORT CIRCUITING !!**

The following table shows the terminal allocations of the incremental pulse generator. Please note that some connections have two wires connected in the same hole :

Colour	Terminal	Function
Green	15	Ch. A
Yellow	7	Ch. B
Pink	-	Not used
Brown	8	+Ub
White	16	0 V
Grey	6	Housing

1. Remove the defect incremental pulse generator from the drive unit.
2. Carefully disconnect the wires of the cable from the terminal block in the socket housing of the reciprocator.
3. Fit the new incremental pulse generator (3) onto the drive shaft of the drive unit. Make sure that the positioning pin (5) fits into the centering block (4) in the incremental pulse generator housing.
4. Carefully tighten the small screw on the hollow shaft collar (7) so that the hollow shaft firmly grips the drive shaft of the drive unit and rotates with it. Some earlier motor units have a flat machined on the drive shaft, so make quite sure that the collar clamping action is effective, otherwise serious damage can be caused to the reciprocator.
5. Make sure that the incremental pulse generator cable cannot get caught in the chain drive !!

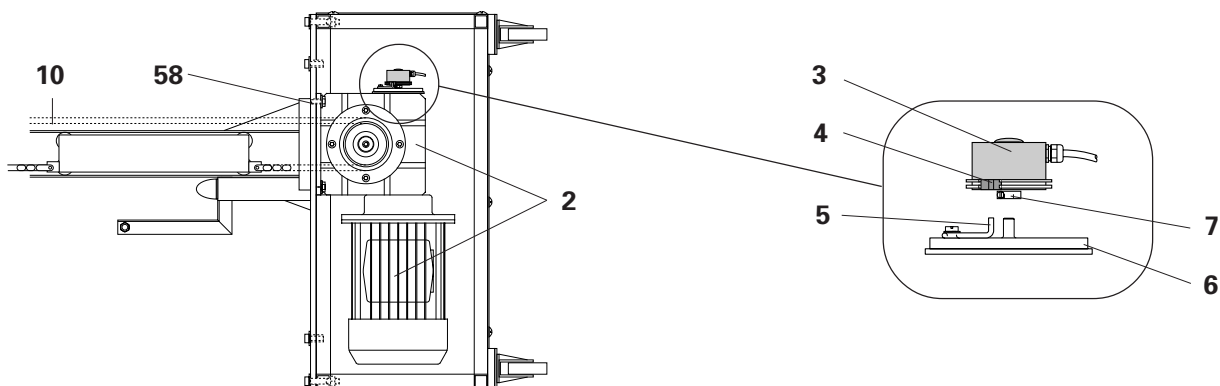
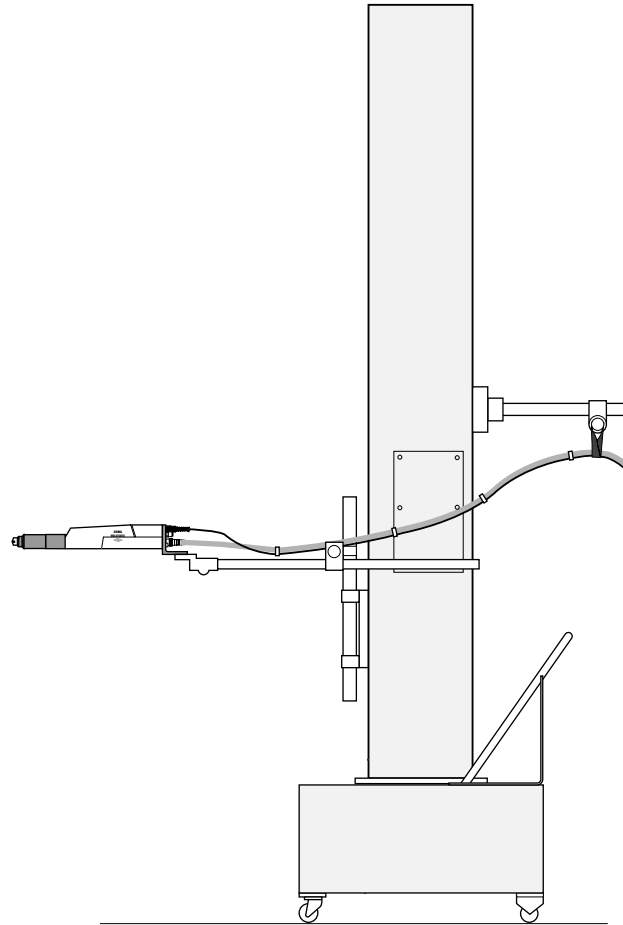

Figure 11

Operating Instructions and Spare Parts List

ACR 2/06/30 Reciprocator



Safety Recommendations

1. *The ACR Reciprocator should only be started up after carefully reading this operating manual. Incorrect setting of the PRC (or MRC) Control unit and the ACR Reciprocator can cause accidents, damage, and faulty operation of the equipment.*
2. **ATTENTION !! The (motor drive) power of the axis is very much stronger than that of any human being!**
*The axis must be made inaccessible during operation (see local safety regulations). When the reciprocator is switched off the carriage can fall to the lowest reversing point under its own weight, therefore, **never stand under the carriage** when the reciprocator is switched off.*
3. The plugs, and sockets of the PRC (or MRC) control module, power unit, and the ACR Reciprocator should only be unplugged when the control module is *disconnected* from the Mains.
4. The connecting cables between the control unit and the reciprocator must be laid out so that they cannot be damaged during operation of the axis.
All movable hoses and cables must also be laid out so that they are neither subjected to any excessive loads nor hang on other parts, even when the reciprocator is at the maximum height of its stroke. *Please observe local safety regulations.*
5. The upper stroke limit must always be set according to the **maximum height** of the reciprocator. If the *wrong stroke height* is set (too high/low) this can cause damage to the booth and/or the reciprocator.
6. When replacing spare parts or carrying out repairs the PRC (or MRC) Control unit must be disconnected from the Mains according to local safety regulations.
7. **Only original** Gema Spare Parts should be used. Use of spare parts from other manufactures *will invalidate* the Gema-Volstatic guarantee conditions.